



**PNEUMATIC ROCKDRILLS**

**DIAMOND DRILLS**

**REPLACEMENT PARTS**



# Features

Large mating faces on components bodies for less wear and longer life

Reduced weight for ease of handling.

## PHQ250JHM Jackleg Specifications

### CYLINDER BORE

3<sup>1</sup>/<sub>8</sub> inches – 79.4mm

### CYLINDER STROKE

2<sup>7</sup>/<sub>8</sub> inches – 73.25mm

### AIR CONSUMPTION

175cfm @90psi – 4.9cu m/m @620kPa

### BLOWS PER MINUTE

2250bpm @ 90psi – 2250bpm @620kPa

### SHANK SIZE - Collared

7<sup>7</sup>/<sub>8</sub> inch x 4<sup>1</sup>/<sub>4</sub> inch - 22mm x 108mm

### LENGTH

Drill 27 inches – 686mm

Leg Retracted 68 inches – 1727mm

Leg Extended 119 inches – 3023mm

### WEIGHT

Drill 81 lb – 32.7kg

Leg 35 lb – 15.9kg

### PHQ250 Jackleg configurations:

- JHM Integral steel muffler
- JHS Standard exhaust
- L Complete with Leg

### PHQ250JHML

Muffled jackleg collared c/w steel retainer & leg

# PHQ250 Jackleg Drill



LOCKING FRONT END

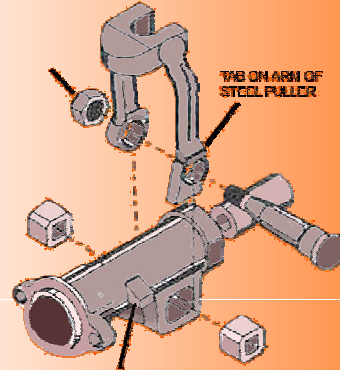

TAB ON STEEL PULLER STOPS AT TAB ON FRONT END



PHQ carries a full range of parts for PHQ250 drills in stock.

All parts made in Canada to precise specifications using only the highest quality tool steel