



# SULLAIR AIR TOOLS



# THE RIGHT TOOL FOR YOUR TOUGH JOB

| Applications   | Tool                           | Sullair Model                        | Class | Weight    | cfm   |
|--|--------------------------------|--------------------------------------|-------|-----------|-------|
| <ul style="list-style-type: none"> <li>Horizontal and overhead applications</li> <li>Industrial applications</li> </ul>  | <b>Chipping Hammer</b>         | <b>MCH-2/3/4</b><br><b>MCH-3S/4S</b> | 15#   | 16-19 lbs | 26-33 |
| <ul style="list-style-type: none"> <li>Cutting and driving large rivets</li> <li>Heavy duty demolition work</li> </ul>   | <b>Rivet Buster</b>            | <b>MRB-8/11</b>                      | 30#   | 30-33 lbs | 44-50 |
| <ul style="list-style-type: none"> <li>Breaking light concrete and other light jobs</li> </ul>                           | <b>Light Pavement Breaker</b>  | <b>MPB-30A</b>                       | 30#   | 35.5 lbs  | 37    |
| <ul style="list-style-type: none"> <li>Concrete bridge decks and general demo work</li> </ul>                            | <b>Light Pavement Breaker</b>  | <b>MPB-35A</b>                       | 40#   | 39 lbs    | 49    |
| <ul style="list-style-type: none"> <li>Concrete road breaking and other general demo work</li> </ul>                     | <b>Medium Pavement Breaker</b> | <b>MPB-60A</b>                       | 60#   | 69.5 lbs  | 48    |
| <ul style="list-style-type: none"> <li>Heavy demo work breaking tough, reinforced concrete</li> </ul>                    | <b>Heavy Pavement Breaker</b>  | <b>MPB-90A</b>                       | 90#   | 92 lbs    | 62    |
| <ul style="list-style-type: none"> <li>Compacting backfill in ditches, trenches, foundations and around poles</li> </ul> | <b>Backfill Tamper</b>         | <b>MBT-6</b>                         | 35#   | 40.5 lbs  | 32    |

# PAVEMENT BREAKERS DESIGNED TO WORK BETTER AND LAST LONGER

*Sullair Pavement Breakers are Designed for Work Efficiency and a Long, Trouble-Free Life*

## High-Wear Parts Reduced

Sullair breakers have eliminated most high-wear parts. Fewer parts mean less wear, less maintenance, and less downtime.

## No Multi-Part Tappet System

Unlike conventional breakers, Sullair breakers have no multi-part tappet system. With no tappet system, which requires three independent impacts, noise is reduced.

## One-Piece, Non-Protrusive Housing

A leak-proof air cushion forms at the end of the piston stroke and stops the piston from direct impact when the tool is not breaking. The elimination of side rods, nuts and springs makes Sullair breakers sleeker and more comfortable to operate.

## Minimal Lubrication Required

With only two parts moving during operation, normal oil carryover from the compressor, combined with moisture in the air, will usually provide sufficient lubrication under normal operating conditions. Manual lubrication before storage is sufficient.

## Interchangeable Parts

Standardization of design permits a high degree of interchangeability of parts between Sullair models.

## Quieter

The piston, impacting directly on the steel shank rather than a tappet, reduces noise level of the breaker.

## Super-Silenced, Anti-Freeze Models

A unique silencer reduces noise levels by 6 dBA, while preventing the tool from freezing, even in the coldest climates.

## Smoother Operation

Reduced kickback is less fatiguing to the operator.

## Simple Latch Design

Durable double roll pin permits easy steel changing.

## Less Air Consumption

The direct impact piston design, non-corrosive distribution valve and one-piece housing dramatically reduce air consumption. You can operate more tools from a single compressor.

## Limited Parts Warranty

Sullair provides a two-year limited warranty on all breaker parts to cover:

- Manufacturing defects
- Normal operation wear
- Hassle Free Warranty:
  - Sullair will ship a new replacement tool for a defective tool during the first six months of warranty

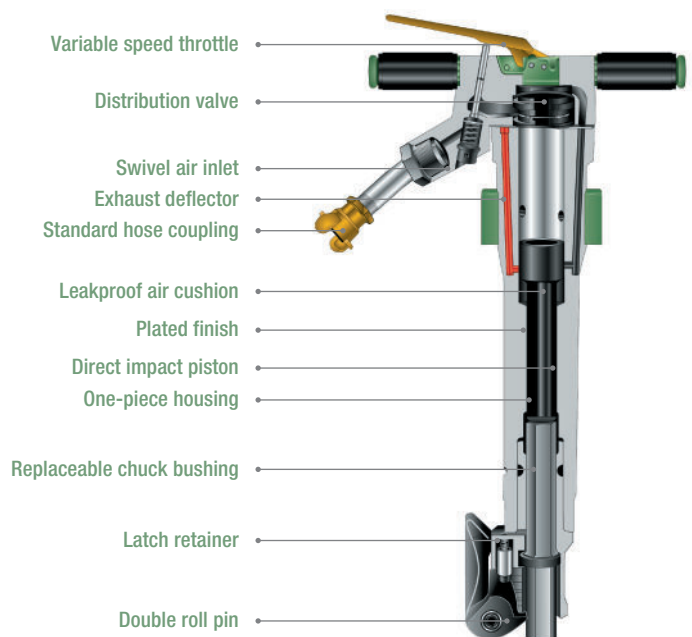

# PAVEMENT BREAKERS

## SULLAIR MPB-90A COMPARED TO A CONVENTIONAL THOR TYPE BREAKER

### 30% less parts than conventional breakers

- Fewer parts to maintain
- Less parts to fail

### Direct impact piston

- No multi-part tappet system like conventional breakers

### One-piece housing

- Elimination of side rods, nuts and spring valves

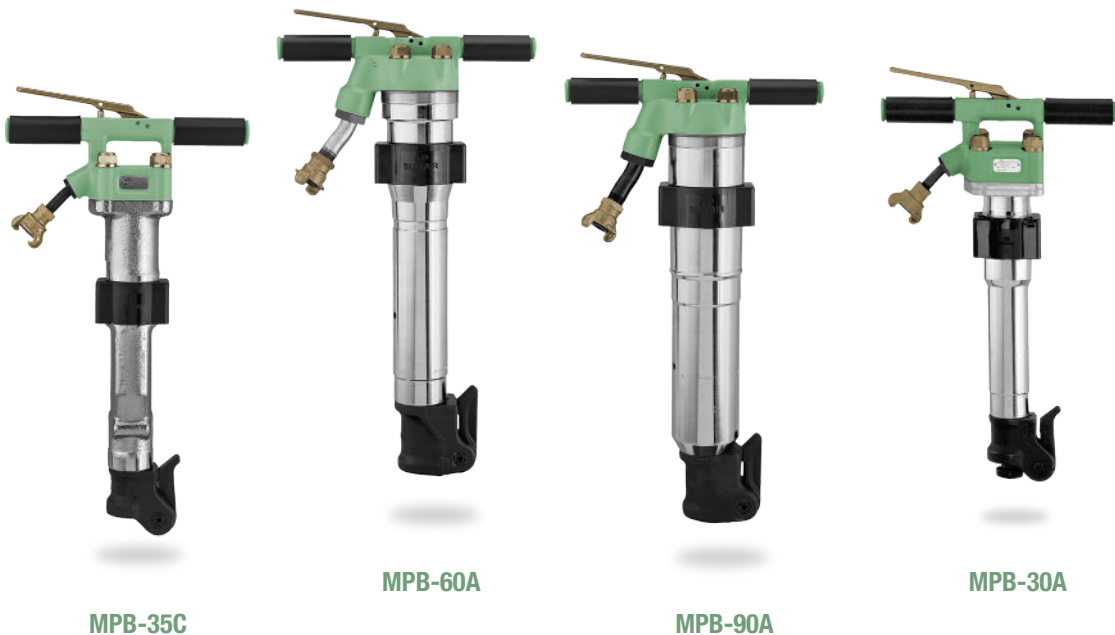
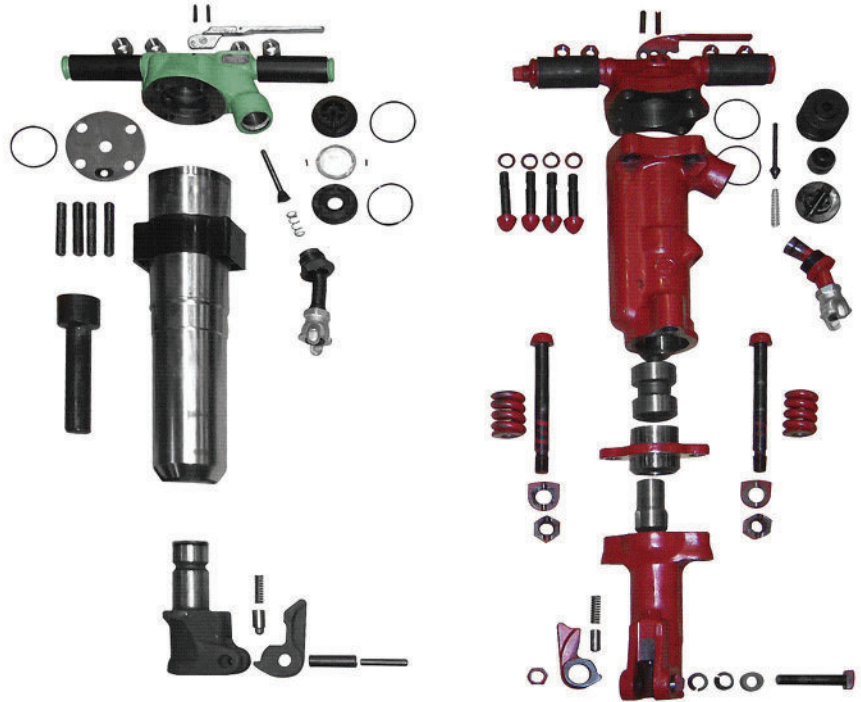

MPB-35C

MPB-60A

MPB-90A

MPB-30A

# TECHNICAL SPECIFICATIONS

## STANDARD T-HANDLE PAVEMENT BREAKER

| MODEL   | PART NUMBER | CHUCK SIZE (in)   | BORE & STROKE (in)  | BLOWS PER MINUTE | AIR CONSUMPTION (cfm) | AIR INLET (NPT) | WEIGHT (lbs) | LENGTH (in) |
|---------|-------------|-------------------|---------------------|------------------|-----------------------|-----------------|--------------|-------------|
| MPB-90A | 68253070    | 1 1/8" x 6"       | 2 7/16" x 5 9/32"   | 1380             | 62                    | 3/4"            | 92           | 27 1/2"     |
|         | 68253071    | 1 1/4" x 6"       | 2 7/16" x 5 9/32"   | 1380             | 62                    | 3/4"            | 92           | 27 1/2"     |
| MPB-60A | 68253072    | 1 1/8" x 6"       | 2 5/32" x 5 5/32"   | 1360             | 48                    | 3/4"            | 69           | 26 1/2"     |
|         | 68253073    | 1 1/4" x 6"       | 2 5/32" x 5 5/32"   | 1360             | 48                    | 3/4"            | 69           | 26 1/2"     |
| MPB-35C | 68253092    | 1" Hex x 4 1/4"   | 1 3/4" x 5 5/16"    | 1200             | 49                    | 3/8"            | 39           | 25 1/2"     |
| MPB-30A | 68253074    | 7/8" Hex x 3 1/4" | 1 25/32" x 3 25/32" | 1850             | 37                    | 3/8"            | 35.5         | 23"         |
|         | 68253075    | 1" Hex x 4 1/4"   | 1 25/32" x 3 25/32" | 1850             | 37                    | 3/8"            | 35.5         | 23"         |

## BREAKER ACCESSORIES

| PART NUMBER   | DESCRIPTION  |
|---|--|
| <b>WHIP HOSE ASSEMBLY, 8' X 1/2" ID. 300 PSI RATED HOSE</b>                     |  |
| 02250152-585  | 3/8" MNPT air inlet swivel   |
| 02250152-584  | 7/8"-24 male thread inlet swivel x 2-lug universal quick connect                 |
| <b>WHIP HOSE ASSEMBLY, 6' X 1/2" ID. 300 PSI RATED HOSE (STEEL HYD. SWIVEL)</b> |  |
| 02250176-106  | 3/8" MNPT steel hydraulic swivel w/ 7/8" bushing x 2-lug universal quick connect |
| <b>WHIP HOSE ASSEMBLY WITH 1/8 PT OILER, 8' X 1/2" ID. 300 PSI RATED HOSE</b>   |  |
| 02250174-410  | 3/8" MNPT air inlet swivel x 2-lug universal, w/ oiler (251309)                  |
| 02250174-411  | 1/2" MNPT air inlet swivel x 2-lug universal, w/ oiler (251309)                  |

# CHIPPING HAMMERS BUILT TO LAST

*The Sullair Chipping Hammer is Designed for Rugged Dependability*

## Four Bolt Backhead

This unique design reduces handle breakage. The common problem of a threaded handle-to-barrel connection coming loose and damaging the handle and internal parts has been eliminated.

## D-handle

The strong "D" configuration is large enough to allow a comfortable, sure grip, even for a gloved hand.

## Minimal Lubrication Required

Because of the Sullair chipping hammer's unique design and materials, normal oil carryover from the compressor, combined with moisture in the air, will usually provide sufficient lubrication under normal operating conditions.

## Rotatable Exhaust Deflector

A durable molded exhaust deflector directs exhaust air away from the operator.

## Standard Oval Return Retainers

Contractors' choice spring retainer. Round collar retainer style available as an accessory.

## User-Friendly, Screw-On Ball Retainer Option

Offering a quick and easy way to change steel, simply by pulling the retainer back, inserting your steel and releasing to lock the steel in place.

## Choice of Stroke Length and Bushings

The Sullair chipping hammer is available in 2", 3" and 4" strokes with either .680 round or .580 hex bushings.

## Air Inlet Option

Two air inlet bushings are furnished:  $\frac{3}{8}$ " NPT and  $\frac{7}{8}$ "-24, internal thread. The bushings provide for versatile hose connections while protecting the handle inlet threads.

## Limited Parts Warranty

Sullair provides a limited parts warranty to cover:

- Two years on the handle and cylinder
- One year on all other parts\*
- Hassle Free Warranty:
  - Sullair will ship a new replacement tool for a defective tool during the first six months of warranty

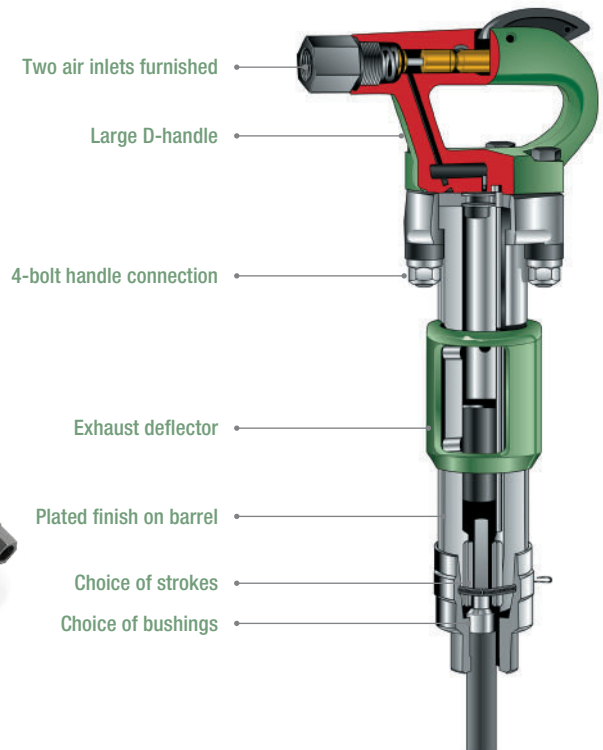

# TECHNICAL SPECIFICATIONS

## CHIPPING HAMMER — STANDARD OVAL RETURN LOCK SPRING RETAINER

| MODEL | PART NUMBER  | CHUCK SIZE (in) | BORE & STROKE (in) | BLOWS PER MINUTE | AIR CONSUMPTION (cfm) | AIR INLET (NPT)   | WEIGHT (lbs) | LENGTH (in) |
|-------|--------------|-----------------|--------------------|------------------|-----------------------|-------------------|--------------|-------------|
| MCH-2 | 68252240-001 | .680 round      | 1½" x 5"           | 3600             | 34                    | ¾" NPT or 7/8"-24 | 16           | 14"         |
|       | 68252243-001 | .580 hex        | 1½" x 5"           | 3600             | 34                    | ¾" NPT or 7/8"-24 | 16           | 14"         |
| MCH-3 | 68252241-001 | .680 round      | 1½" x 5¾"          | 2280             | 33                    | ¾" NPT or 7/8"-24 | 18           | 15¼"        |
|       | 68252244-001 | .580 hex        | 1½" x 5¾"          | 2280             | 33                    | ¾" NPT or 7/8"-24 | 18           | 15¼"        |
| MCH-4 | 68252242-001 | .680 round      | 1½" x 4¼"          | 1800             | 30                    | ¾" NPT or 7/8"-24 | 18           | 16½"        |
|       | 68252245-001 | .580 hex        | 1½" x 4¼"          | 1800             | 30                    | ¾" NPT or 7/8"-24 | 18           | 16½"        |

## CHIPPING HAMMER — SCREW-ON BALL RETAINER (NO SPRINGS REQUIRED)

| MODEL  | PART NUMBER  | CHUCK SIZE (in) | BORE & STROKE (in) | BLOWS PER MINUTE | AIR CONSUMPTION (cfm) | AIR INLET (NPT)   | WEIGHT (lbs) | LENGTH (in) |
|--------|--------------|-----------------|--------------------|------------------|-----------------------|-------------------|--------------|-------------|
| MCH-3S | 68252247-004 | .680 round      | 1½" x 3¾"          | 2280             | 33                    | ¾" NPT or 7/8"-24 | 18           | 15¼"        |
|        | 68252250-004 | .580 hex        | 1½" x 3¾"          | 2280             | 33                    | ¾" NPT or 7/8"-24 | 18           | 15¼"        |
| MCH-4S | 68252248-004 | .680 round      | 1½" x 4¼"          | 1800             | 30                    | ¾" NPT or 7/8"-24 | 18           | 16½"        |
|        | 68252251-004 | .580 hex        | 1½" x 4¼"          | 1800             | 30                    | ¾" NPT or 7/8"-24 | 18           | 16½"        |

## CHIPPING HAMMER — RETAINERS AND ACCESSORIES

| PART NUMBER   | DESCRIPTION   |
|---|---|
| <b>REPLACEMENT RETAINERS AND LOCK SPRINGS</b>                   |   |
| 68722235  | Retainer, for oval collar steel—chrome finish—standard                            |
| 250012-526  | Retainer, for round collar steel w/bumper   |
| 250018-894  | Rubber bumper replacement for round collar retainer                               |
| 250021-222  | Retainer, universal ball type (spring)  |
| 250012-530  | Lock Spring, heavy duty   |
| 250013-916  | Lock Spring, plastic  |
| 68780341  | Retainer, for oval collar steel—chrome finish—standard                            |
| 68722755  | Retainer MLC, oval collar round shank steel                                       |
| 68722756  | Retainer MLC, oval collar hex shank steel   |
| <b>WHIP HOSE ASSEMBLIES, 8' X ½" ID. 300 PSI RATED HOSE</b>     |   |
| 02250152-585  | ¾" MNPT air inlet swivel  |
| 02250152-584  | 7/8"-24 male thread inlet swivel x 2-lug universal quick connect                  |
| <b>WHIP HOSE WITH SWING COUPLING, 8' X ½" ID HOSE W 1' WHIP</b> |   |
| 02250139-711  | 7/8"-24 male thread air inlet with swing coupling x 2-lug universal quick connect |
| 02250139-712  | ¾" MNPT air inlet with swing coupling x 2-lug universal quick connect             |

# RIVET BUSTER

*The Power for Cutting Off Large Rivet Heads, Heavy Duty Chipping and Concrete Breaking*

## Applications Include:

- Bridge jobs
- Steel structure maintenance
- Railroad car repair
- Shipyards
- Petrochemical plants
- Demolition work

## D-handle with Inside Trigger

Handle design provides comfort and control to the operator in demolition applications.

## Variable Throttle Control

Allows variable speed control for maximum production.

## Muffler and Screened Inlet Bushing Standard

Provides quieter operation and filters the inlet from contaminating particles.

## Interchangeable Parts Provide Flexibility

Interchangeable parts\* reduce inventory and increase parts versatility.

## Simplified Control Valve

Allows for smoother operation in dirty conditions through precisely engineered tolerances.

## Lubrication

Rivet Busters require inline lubrication.

## Limited Parts Warranty

Sullair provides a 90-day limited parts warranty for all tool parts to cover:

- Manufacturing defects



## TECHNICAL SPECIFICATIONS

| RIVET BUSTERS |              |                 |                    |                  |                       |                 |              |             |
|---------------|--------------|-----------------|--------------------|------------------|-----------------------|-----------------|--------------|-------------|
| MODEL         | PART NUMBER  | CHUCK SIZE (in) | BORE & STROKE (in) | BLOWS PER MINUTE | AIR CONSUMPTION (cfm) | AIR INLET (NPT) | WEIGHT (lbs) | LENGTH (in) |
| MRB-8         | 02250094-894 | 11 x Jumbo      | 1 3/16" Round x 8" | 1140             | 44                    | 1/2" NPT        | 30           | 22 1/2"     |
| MRB-11        | 02250094-895 | 11 x Jumbo      | 1 3/16" Round x 8" | 850              | 50                    | 1/2" NPT        | 33           | 25 1/2"     |

| RIVET BUSTERS – RETAINERS AND ACCESSORIES                              |   |
|--|---|
| PART NUMBER  | DESCRIPTION   |
| 02250166-693   | Rivet Buster Lower End Kit                                      |
| 250035-776   | Retainer  |
| 250029-072   | Upper Sleeve 11X  |
| 250013-625   | Lower Sleeve 11X  |
| 250013-626   | Bumper  |
| 250013-594   | Retainer spring   |
| WHIP HOSE ASSEMBLY WITH 1/8 PT OILER, 8' X 1/2" ID. 300 PSI RATED HOSE |   |
| 02250174-411   | 1/2" MNPT air inlet swivel x 2-lug universal, w/ oiler (251309) |



# BACKFILL TAMPER

*The Sullair MBT-6 Backfill Tamper Gives You All the Power for Compacting at a Speed Which Allows Comfortable Control*

## Applications

The Sullair MBT-6 backfill tamper is the ideal tool for compacting backfill around utility poles, foundations and other structures. It quickly and efficiently compacts backfill soil excavated to perform service line repair before patching the pavement.

## Rotatable Exhaust Deflector

A durable molded exhaust deflector aims the exhaust away from the operator.

## Standard Steel 6" Butt

A 6" diameter solid steel butt is standard. Optional butts for special applications are available. The butt is held onto the piston rod with a hex head clamp screw for ease of assembly and removal.

## Smooth Finish

Plated barrel promotes easy clean-off of backfill materials.

## Minimal Lubrication Required

With the design features and premium materials of the MBT-6, normal oil carryover from the compressor, combined with the moisture in the air, will supply sufficient lubrication under normal operating conditions.

## No Packing Adjustment

There is no packing adjustment necessary for the Sullair MBT-6. The double seals retain their effectiveness for the life of the packing.

## Limited Warranty

Sullair provides a one-year limited warranty.

- Hassle Free Warranty:
  - Sullair will ship a new replacement tool for a defective tool during the first six months of warranty



# TECHNICAL SPECIFICATIONS

| BACKFILL TAMPER |              |                        |                    |                  |                       |                   |              |             |
|-----------------|--------------|------------------------|--------------------|------------------|-----------------------|-------------------|--------------|-------------|
| MODEL           | PART NUMBER  | BUTT END DIAMETER (in) | BORE & STROKE (in) | BLOWS PER MINUTE | AIR CONSUMPTION (cfm) | AIR INLET (NPT)   | WEIGHT (lbs) | LENGTH (in) |
| MBT-6           | 02250053-832 | 6" Steel Butt End      | 1½" x 5½"          | 500              | 32                    | ¾" NPT or 7/8"-24 | 40.5         | 48¾"        |

| BACKFILL TAMPER — OPTIONAL BUTT ENDS AND ACCESSORIES |                                    |
|--|------------------------------------|
| PART NUMBER  | DESCRIPTION                        |
| 68722625   | 6" Dia. Butt—Steel                 |
| 250034-467   | Half-Moon Pole Butt—Malleable Iron |
| 250034-783   | 6" Dia. Butt—Malleable Iron        |
| 250034-784   | 4" Dia. Butt—Aluminum              |
| 250034-785   | 3" Dia. Butt—Aluminum              |
| 250012-703   | Screw, Taper                       |

| WHIP HOSE ASSEMBLIES, 8' X ½" ID. 300 PSI RATED HOSE |  |
|--|--|
| 02250152-585   | ¾" MNPT air inlet swivel   |
| 02250152-584   | 7/8"-24 male thread inlet swivel x 2-lug universal quick connect |

| WHIP HOSE WITH SWING COUPLING, 8' X ½" ID HOSE W 1' WHIP |   |
|--|---|
| 02250139-711   | 7/8"-24 male thread air inlet with swing coupling x 2-lug universal quick connect |
| 02250139-712   | ¾" MNPT air inlet with swing coupling x 2-lug universal quick connect             |



Backfill Tamper Butts, like all Sullair accessories, are made specifically for Sullair tools, so proper fit and performance are assured. Our selection includes: (1) 6" Malleable Iron, (2) 6" Steel Butt (standard), (3) 4" Aluminum Butt, (4) Pole Butt Half Moon and (5) 3" Aluminum Butt.

## Sullair Hassle Free Warranty

Enjoy the advantages of reduced downtime and cost of ownership with our industry-leading Hassle Free Warranty. How it works: Sullair will ship a new replacement tool for a defective tool during the first 6 months of ownership.

# GENUINE ACCESSORIES AND SWING VALVES

## Sullair Swing Valve Couplings Provide

- Safe and easy air shut-off at the tool
- No need to turn off the compressor
- Safely bleeds the air from the tool
- Saves time, saves money

## Easy Tool Changes

- Change the tool quickly
- Change the steels safely
- Prevents accidental firing of tool

## Full Flow to Tool

- Full throat valve, no flow restriction
- Smooth bore no pressure loss in valve

## Complete Eight Foot Whip Hose Comes with One Optional Tool Connector

- $\frac{7}{8}$ " x 24 Male fine thread
- $\frac{1}{2}$ " MNPT Male thread
- $\frac{3}{8}$ " MNPT Male thread
- 2-lug universal coupling
- Entire whip is complete with swing valve and 2-lug connector

## Quick and Sure Connections

- Connect and disconnect under pressure
- No extra effort against line pressure
- Locking sleeve prevents accidental on/off
- When in "locked off" position, tool hose is vented. #1
- Full flow when in "locked on" position. #2

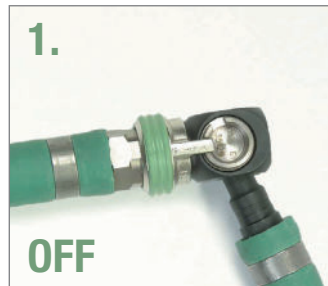

If you're using Sullair tools, get the performance you paid for.  
Use only genuine Sullair accessories.

# PNEUMATIC TOOL ACCESSORIES

## LINE OILER AND IN-LINE FILTER

| PART NUMBER  | DESCRIPTION                                 |
|--------------|---|
| 251309       | 1/8 Pint capacity (1/2" FNPT-Pressure Feed) |
| 251310       | 1/4 Pint capacity (3/4" FNPT-Pressure Feed) |
| 251311       | 1/2 Pint capacity (3/4" FNPT-Pressure Feed) |
| 251312       | 1/2 Pint capacity (1" FNPT-Pressure Feed)   |
| 251313       | 1 Pint capacity (1" FNPT-Pressure Feed)     |
| 251314       | 1/2 Pint capacity (1" FNPT-Constant Feed)   |
| 251315       | 1 Pint capacity (1" FNPT-Constant Feed)     |
| 02250138-177 | In-line hose filter (1/2" FNPT)             |
| 250012-263   | Wet Kit for MRD-55 Rock Drill               |

## TOOL STAND

| PART NUMBER  | DESCRIPTION        |
|--------------|--------------------|
| 02250219-140 | Tool Stand, 3 tool |
| 02250219-139 | Tool Stand, 7 tool |

## BUTTS FOR MBT-6 BACKFILL TAMPER

| PART NUMBER | DESCRIPTION                          |
|-------------|--------------------------------------|
| 68722625    | 6" Dia. Butt—Steel                   |
| 250034-467  | Half-Moon Pole Butt — Malleable Iron |
| 250034-783  | 6" Dia. Butt — Malleable Iron        |
| 250034-784  | 4" Dia. Butt — Aluminum              |
| 250034-785  | 3" Dia. Butt — Aluminum              |
| 250012-703  | Screw, Taper                         |

## AIR INLET SWIVELS FOR CHIPPERS, TAMPERS

| PART NUMBER | DESCRIPTION                     |
|-------------|---------------------------------|
| 250012-531  | 7/8"-24 thread — 1/2" hose barb |
| 250012-532  | 3/4" NPT — 1/2" hose barb       |
| 250012-533  | 1/2" NPT — 1/2" hose barb       |

## RETAINERS AND ACCESSORIES FOR CHIPPING HAMMERS

| PART NUMBER | DESCRIPTION   |
|-------------|---|
| 68722235    | Retainer, for oval collar steel—chrome finish       |
| 250012-526  | Retainer, for round collar steel w/bumper           |
| 250018-984  | Rubber bumper replacement for round collar retainer |
| 250021-222  | Retainer, universal ball type (spring)              |
| 250012-530  | Lock Spring, heavy duty                             |
| 250013-916  | Lock Spring, plastic                                |
| 68780341    | Retainer, universal ball type (screw-on)            |
| 68722755    | Retainer MLC, oval collar round shank steel         |
| 68722756    | Retainer MLC, oval collar hex shank steel           |

## RETAINERS AND ACCESSORIES FOR RIVET BUSTERS

| PART NUMBER  | DESCRIPTION                 |
|--------------|-----------------------------|
| 250035-776   | Retainer                    |
| 250029-072   | Upper Sleeve 11X            |
| 250013-625   | Lower Sleeve 11X            |
| 250013-626   | Bumper                      |
| 250013-594   | Retainer spring             |
| 02250166-693 | Kit, Rivet Buster Lower End |

## AIR HOSE, COUPLINGS, FITTINGS AND ACCESSORIES, 300 psig RATED HOSE

| PART NUMBER  | DESCRIPTION                                     |
|--------------|---|
| 02250152-581 | 50' 2-lug universal quick connect at both ends  |
| 02250152-583 | 100' 2-lug universal quick connect at both ends |

## WHIP HOSE ASSEMBLIES, 8' X 1/2" ID. 300 psig RATED HOSE

| PART NUMBER  | DESCRIPTION  |
|--------------|--|
| 02250152-585 | 3/8" MNPT air inlet swivel                                       |
| 02250152-586 | 1/2" MNPT air inlet swivel x 2-lug universal quick connect       |
| 02250152-584 | 7/8"-24 male thread inlet swivel x 2-lug universal quick connect |

## WHIP HOSE ASSEMBLIES, 6' X 1/2" ID. 300 psig RATED HOSE (STEEL HYD. SWIVEL)

| PART NUMBER  | DESCRIPTION  |
|--------------|--|
| 02250176-106 | 3/8" MNPT steel hydraulic swivel w/ 7/8" bushing x 2-lug universal quick connect |

## WHIP HOSE ASSEMBLY WITH 1/8 PT OILER, 8' X 1/2" ID. 300 psig RATED HOSE

| PART NUMBER  | DESCRIPTION  |
|--------------|--|
| 02250174-410 | 3/8" MNPT air inlet swivel x 2-lug universal, w/oiler (251309)       |
| 02250174-411 | 1/2" MNPT air inlet swivel x 2-lug universal, w/oiler (251309)       |
| 02250174-412 | 7/8"-24 male thread inlet swivel x 2-lug universal, w/oiler (251309) |

## WHIP HOSE WITH SWING COUPLING, 8' X 1/2" ID HOSE W 1' WHIP

| PART NUMBER  | DESCRIPTION   |
|--------------|---|
| 02250139-711 | 7/8"-24 male thread air inlet with swing coupling x 2-lug universal quick connect |
| 02250139-712 | 3/8" MNPT air inlet with swing coupling x 2-lug universal quick connect           |
| 02250139-713 | 1/2" MNPT air inlet with swing coupling x 2-lug universal quick connect           |
| 02250139-714 | 2-lug universal air inlet with swing coupling x 2-lug universal quick connect     |

## ADDITIONAL 1' WHIP HOSE FOR ABOVE SWING COUPLINGS

| PART NUMBER  | DESCRIPTION                      |
|--------------|----------------------------------|
| 02250139-707 | 7/8"-24 fitting and valve plug   |
| 02250139-709 | 1/2" MNPT fitting and valve plug |
| 02250139-710 | 2-lug fitting and valve plug     |

## BULK HOSE ON REEL

| PART NUMBER  | DESCRIPTION                              |
|--------------|--|
| 02250152-580 | 3/4" x 400' Sullair Green Hose — 300 psi |

## HOSE FITTINGS, CLAMPS AND REPAIR KITS

| PART NUMBER  | DESCRIPTION  |
|--------------|--|
| 250031-650   | 3/4" Hose barb, 2-lug universal quick connect  |
| 250031-654   | 3/4" Hose barb, 2-bolt style clamp   |
| 02250113-961 | Coupling, 2-lug universal quick connect — 3/8" MNPT  |
| 02250140-797 | Coupling, 2-lug universal quick connect — 3/8" FNPT  |
| 02250126-794 | Coupling, 2-lug universal quick connect — 1/2" MNPT  |
| 040383       | Coupling, 2-lug universal quick connect — 3/4" FNPT  |
| 250031-648   | Coupling, 2-lug universal quick connect — 3/4" MNPT  |
| 250015-228   | Gasket, rubber — for 2-lug universal coupling (package of 50) sold per pkg   |
| 250031-659   | Clip, hose coupling, safety (package of 25) sold per pkg   |
| 02250119-544 | HOSE REPAIR KIT (includes following): 50 ea. 1/2" hose clamp, 40 ea. 3/4" hose clamp, 6 ea. 1/2" hose mender, 6 ea. 3/4" hose mender, and 1 ea. Toll pincher long handle |
| 02250119-543 | Hose clamp pincher tool (long handle)  |
| 02250119-541 | 1/2" Hose mender (tube)  |
| 02250119-542 | 3/4" Hose mender (tube)  |
| 02250119-863 | 3/4" Hose clamp (package of 100)   |