

Dimension™ 650

Multiprocess Welding Power Source 

Quick Specs

Heavy Industrial Applications

Fabrication and construction
 Heavy manufacturing
 MRO — maintenance/repair
 Pressure tank/vessel fabrication
 Shipbuilding
 Refineries and foundries
 Railcar manufacturing
 Earth-moving equipment manufacturing

Processes

MIG (GMAW)
 Flux-cored (FCAW)
 Submerged arc (SAW)
 Stick (SMAW)
 TIG (GTAW)
 Air carbon arc (CAC-A)
 cutting and gouging
 Rated: 3/8-inch carbons
 Induction heating*

Input Power 380/460 V, 50/60 Hz or 575 V, 60 Hz, 3-phase power

Rated Output 650 A at 44 VDC, 100% duty cycle

Output Range 15–815 A, 10–65 V

Net Weight 158 lb. (71.7 kg)

ArcReach (recommended option)

Remote voltage control without a control cable

*ArcReach model only with ArcReach Heater.

Big capabilities in a smaller package.

Developed for harsh environmental conditions and output requirements that range from power-intensive to precise.

An unbeatable combination of durability, output, efficiency and capability — all in a smaller, easier-to-handle package. Inside its tough, corrosion-resistant, all-aluminum case is big power for heavy welding jobs and carbon arc gouging.

In addition to excellent stick and Lift-Arc™ TIG, the Dimension 650 also has excellent short-arc MIG characteristics for precise thin-metal welding performance.



Rugged and Durable Inside and Out



Improved Arc Performance



Smaller and Lighter



Increased Uptime



Improved Jobsite Safety



Maximize Fleet Compatibility



ArcReach® Heater Compatibility

ArcReach®

Remote voltage control at the wire feeder or remote without needing a control cord. See page 3 for more information.



Power source is warrantied for three years, parts and labor. Original main power rectifier parts are warrantied for five years.



Miller Electric Mfg. LLC
 An ITW Welding Company
 1635 West Spencer Street
 P.O. Box 1079
 Appleton, WI 54912-1079 USA

Equipment Sales US and Canada
 Phone: 866-931-9730
 FAX: 800-637-2315
 International Phone: 920-735-4554
 International FAX: 920-735-4125

MillerWelds.com



Dimension™ 650 Advantages

Withstands harsh environments



Rugged and durable inside and out

All-aluminum construction helps the machine resist corrosion for long life.

Exclusive protection input inductor protects machine's performance and reliability from "dirty" input power.

Wind Tunnel Technology™ Internal air flow that protects electrical components and PC boards from dirt, dust, debris... greatly improving reliability

Fan-On-Demand™ operates only when needed reducing noise, power consumption, and the amount of airborne contaminants pulled through the machine.

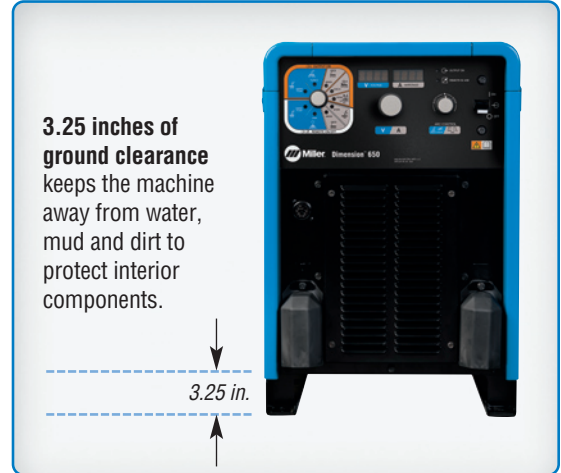

3.25 inches of ground clearance keeps the machine away from water, mud and dirt to protect interior components.

Smaller and lighter



More portable and takes up less floor space

Reduced size and weight results in an easier-to-handle package that exceeds the welding performance of larger, heavier machines. Weighing in at 158 pounds (71.7 kg), the Dimension 650 is 3.5 times lighter than the Dimension 652, making it easier to move around the shop, jobsite, or shipyard. It also uses 40 percent less floor space.

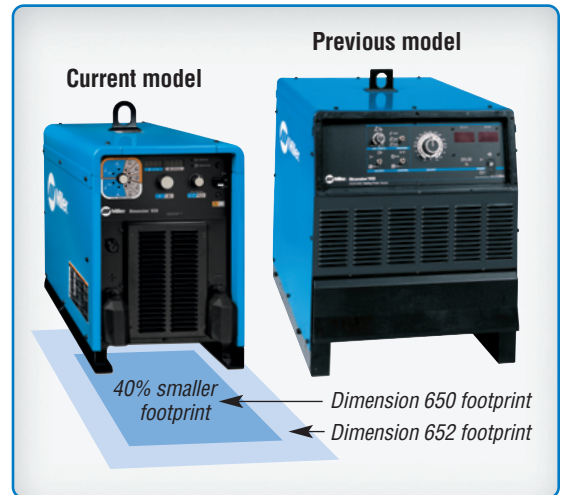

Current model

Previous model

40% smaller footprint

Dimension 650 footprint

Dimension 652 footprint

Power efficient



Uses 32% fewer amps than previous model

High electrical efficiency and excellent power factor mean that you can get more welding done using less power. On 460-volt input power, the Dimension 650 draws only 43 amps at rated load and can operate on a 50-amp service. Four machines can work at maximum loads simultaneously on a 200-amp service, drawing less amperage than three previous models.

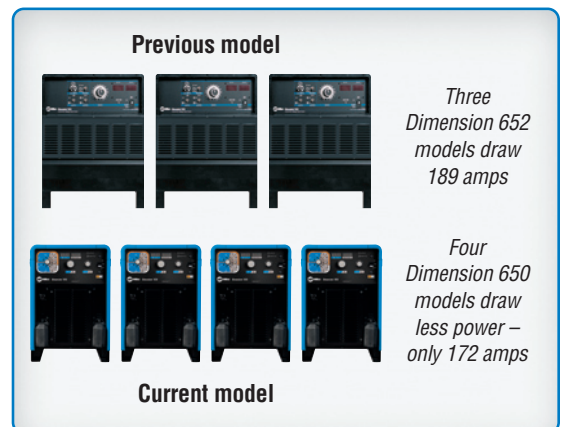

Previous model

Three Dimension 652 models draw 189 amps

Four Dimension 650 models draw less power – only 172 amps

Current model

Dimension™ 650 Advantages

Improved arc performance



Power and precision

High-quality performance from power-intensive to precise. Knowing quality welds begin with a quality arc, we've significantly improved the performance in all welding processes and made it easy to fine tune the arc to match your personal preferences and welding style.

Gouging mode provides 800 amps of usable power, a full 650 amps of power at 100 percent duty cycle. Perfect for heavy gouging with 3/8-inch carbons.

Three wire modes (GMAW/FCAW/SAW) for simplified setup and optimized arc performance.

- Solid and flux-cored wires with gas offer exceptional short-arc MIG precision to weld thin metals with less risk of distortion or burn-through, and premium flux-cored welding with gas.
- Flux-cored (self-shielded) welding performance is exceptional, especially with wires commonly found in infrastructure construction.
- Sub arc mode provides capability to retrofit into non-digital sub arc applications.



Weld process switch with Gouge mode, three Wire modes, Stick mode and Lift-Arc TIG mode.

Arc control for additional fine-tuning in Stick or Solid Wire modes.

Excellent stick and Lift-Arc™ TIG performance.

Arc control is beneficial when welding with stick and solid wires for easier fine-tuning of tough-to-weld materials and out-of-position applications.

Dimension™ 650 ArcReach® Advantages



Increased uptime

No more expenses related to maintaining or replacing easily damaged control cords because the weld cables are used to communicate weld parameters between the wire feeder and power source.



Improved jobsite safety

The chances of slip, trip or fall injuries are decreased because ArcReach technology allows weld operators to make parameter changes at the wire feeder/remote instead of having to travel through multistory and cluttered jobsites back to the power source.



Auto-Process Select

Decrease the chance of an incorrect weld process being used because Auto-Process Select™ automatically sets the power source to the correct weld process based on the polarity applied to the weld accessory.



ArcReach Heater compatibility

Take charge of your field preheat and bakeout applications up to 600 degrees Fahrenheit (315°C). This system uses induction heating to generate heat in workpieces, so welders can do their own preheating quickly and safely.

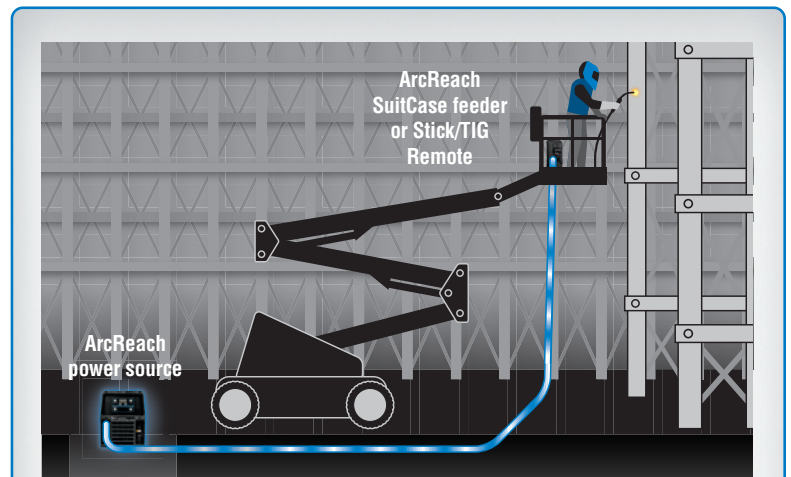

ArcReach

Remote control of the power source without a cord.

ArcReach accessories

For MIG or flux-cored welding — ArcReach® SuitCase® feeders

- Remote voltage control
- Polarity indication
- Auto-Process Select™

For stick or TIG welding — ArcReach® Stick/TIG Remote

- Remote amperage control
- Arc control for stick
- Polarity indication
- Auto-Process Select™



Dimension™ 650 Features



Digital meters with SunVision™ technology enable welding parameters to be viewed with greater clarity than analog meters — at virtually any angle. Meters can be seen clearly even in direct sunlight.

Meters display

- Process settings for quick and easy setup
- Preset and actual amperage

LED process indicator. Front panel process selections are illuminated with an LED that identifies the active process. This enables the selected weld process to be seen at a distance from the power source.

- Gouging mode is an optimized stick position for better gouging performance
- Three wire modes (GMAW/FCAW/SAW) for simplified setup and optimized arc performance
 - Solid and flux-cored wires with gas
 - Flux-cored (self-shielded)
 - Sub arc
- Stick mode for all electrode types
- Lift-Arc™ TIG

Standard 14-pin receptacle with Auto-Remote Sense™ for simple connection of remote controls and wire feeders.



Durable weld cable connections

- Serrated hardware for single-wrench application
- Easy double weld cable installation
- Flexible, protective covers prevent incidental contact



Remote in use indicator. On standard Dimension 650 models the remote in use indicator means a device (remote control or wire feeder with a remote control) is connected to the 14-pin connector.



Back panel. 20 amps of 120-volt power to run power tools — like grinders, chop saws, drills and lights.

Dimension 650 ArcReach additional features



Remote in use indicator

provides convenient feedback indicating an ArcReach wire feeder is controlling the power source. While under ArcReach control, process and voltage/amperage adjustments are locked out, preventing accidental changes by personnel other than the welding operator.

Auto-Bind automatically establishes an exclusive communication between the power source and the wire feeder, using the existing weld cables upon system power up.



Fleet compatibility.

ArcReach-equipped power sources and wire feeders work with non-ArcReach equipment; however, the complete ArcReach benefit is only realized with the ArcReach system.

Front-panel-mounted power switch

is easy to access when in racks or manufacturing cells.



Arc control is active in the stick and solid-wire processes. It allows the operator to customize arc characteristics to match preference, electrode and joint design from a softer arc with more fluid puddle to a stiffer arc with a more controllable puddle. The Star setting is optimized for most applications and pointing the control at Soft or Stiff is optimal for most arc preferences. Control is fully adjustable from 0 to 25 Soft or 0 to 25 Stiff.

Specifications (Subject to change without notice.)



Amperage/Voltage Ranges	Rated Output	Amps Input at Rated Output, 50/60 Hz	Max. Open-Circuit Voltage	Dimensions	Net Weight
		380 V 460 V 575 V* KVA KW			
10–815 A in CC mode 10–44 V in CV mode 10–65 V in SAW mode	650 A at 44 VDC, 100% duty cycle	53.2 42.8 34.3 34 30.7	87	H: 28.187 in. (716 mm) (including lift eye) W: 16.687 in. (424 mm) D: 31.625 in. (803 mm)	158 lb. (71.7 kg)

*Dimension 650 with 575-volt input is 60 Hz only.

Wire Feeder Options

Portable Suitcase-Style Feeders

ArcReach® SuitCase® 8 and 12 See literature M/6.55

These voltage-sensing feeders are designed to run off of arc voltage from almost any welding power source. The ArcReach SuitCase 8 utilizes an 8-inch spool of wire and fits through a 14-inch manhole/manway, while the ArcReach SuitCase 12 adds the capability to utilize 12-inch spools and is more commonly used in structural steel and fabrication.

SuitCase® 12RC See literature M/6.45

Standard remote voltage control saves the operator a trip back to the power supply for welding adjustments. For applications where the feeder is within 100 feet of the power source and control cords are acceptable.

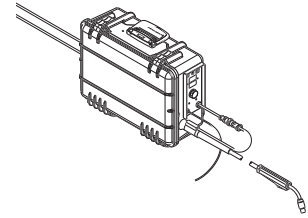

Bench-Style Feeders

20 Series Feeders See literature M/11.0

Simple and cost-effective feeders for industrial manufacturing and fabricating.

70 Series Feeders See literature M/3.0

74S — Standard, simple feeders for most heavy-industrial applications.

74D — Provides increased accuracy and control of the most common weld parameters.

74 MPa Plus — Adds push-pull aluminum capabilities. Optimized for use with XMT® MPa, Invision™ MPa and Dimension™ 650 power sources.

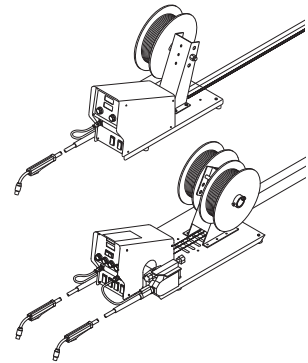

Boom-Style Feeders

70 Series Swingarc™ See literature M/13.11

Swingarc single and dual boom-mounted wire feeders bring an extra dimension of flexibility and efficiency to weld stations dealing with large weldments, or wherever operator mobility is required.

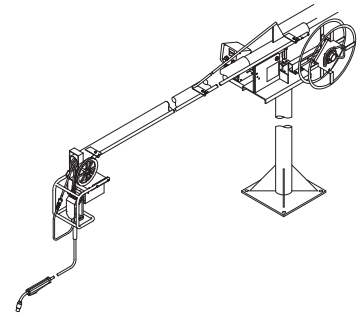

Aluminum Push-Pull Feeders and Guns

XR-AlumaFeed® SuitCase® See literature DC/34.0

Cost-effective push-pull feeder for industrial applications.

XR-Aluma-Pro™ Gun See literature M/1.71

Robust professional grade gun has the highest duty-cycle rating in its class.

XR™-Pistol-Pro Gun See literature M/1.74

Exceptional aluminum welding results for heavy industrial applications.

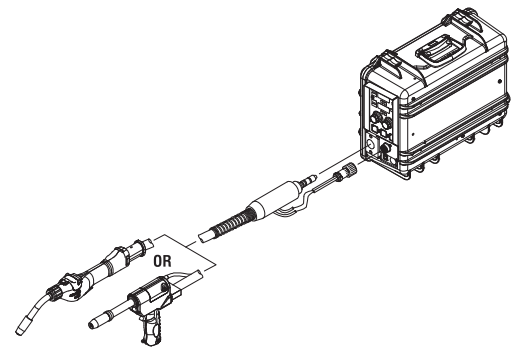

Hard Automation

70 Series Remote Configurations See literature M/3.0

Remote wire feeder control box and wire drive assembly for non-Miller boom applications.

Sub Arc mode provides capability to retrofit into non-digital sub arc applications. 115-volt adapter cord for legacy 14-pin accessories is required.

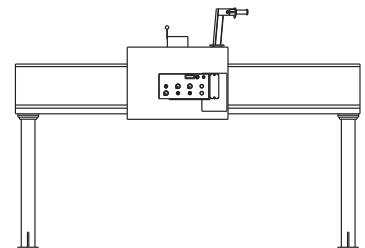



Dimension™ 650 ArcReach® Rack 907701
 Conveniently houses four Dimension 650 ArcReach power sources for multiple welders. Features include:

- Provision to parallel power sources on common work connections
- Two lifting eyes for transportation
- Rugged skids for dragging or pushing



Running Gear Cylinder Rack 300408
 Small footprint and easily maneuverable, with cylinder rack low enough that you do not have to lift bottles.

Adapter Cord 301259
 115-volt cord for legacy 14-pin accessories. Required to connect to HDC 1500.

Process Control Selector 042872
 Allows you to easily change weld processes without changing cables — from TIG to MIG or TIG to stick. Also includes features of polarity control. Can be used with any constant-current, constant-voltage or multiprocess CC/CV welding power source.



Industrial MIG 4/0 Kit 300390
 Consists of flowmeter regulator with 10-foot (3 m) gas hose, 10-foot (3 m) 4/0 feeder weld cable with lugs, and 15-foot (4.6 m) work cable with 600-amp C-clamp.

Remote Controls and Switches



When paired with an ArcReach power source, provides remote control of the power source without a cord — saving time and money. See literature AY/14.5.



For remote current and contactor control. Receiver plugs directly into the 14-pin receptacle of Miller machine. 90-foot (27.4 m) operating range.



Wireless Remote Hand Control 300430
 For remote current and contactor control. Receiver plugs directly into the 14-pin receptacle of Miller machine. 300-foot (91.4 m) operating range.



RFCS-14 HD Foot Control 194744
 Maximum flexibility is accomplished with a reconfigurable cord that can exit the front, back or either side of the pedal. Foot pedal provides remote current and contactor control. Includes 20-foot (6 m) cord and 14-pin plug.



RHC-14 Hand Control 242211020
 20 ft. (6 m) cord
242211100
 100 ft. (30.5 m) cord
 Miniature hand control for remote current and

contactor control. Dimensions: 4 x 4 x 3.25 inches (102 x 102 x 83 mm). Includes cord and 14-pin plug.



RCC-14 Remote Contactor and Current Control 151086
 East/west rotary-motion fingertip control attaches to TIG torch using two hook-and-loop fasteners. Allows complete current and contactor control at operator's fingertips. Includes 26.5-foot (8 m) cord and 14-pin plug.



RCCS-14 Remote Contactor and Current Control 043688
 North/south rotary-motion fingertip control attaches to TIG torch using two hook-and-loop fasteners. Great for applications that require a finer amperage control. Includes 26.5-foot (8 m) cord and 14-pin plug.



RMLS-14 129337
 Momentary- and maintained-contact rocker switch for contactor control. Push forward for maintained contact and backward for momentary contact. Includes 26.5-foot (8 m) cord and 14-pin plug.

Extension Cables for 14-Pin Plugs to 14-Pin Sockets

242208025 25 ft. (7.6 m)

242208050 50 ft. (15.2 m)

242208080 80 ft. (24.4 m)

Extension cables make a direct connection between the power source and remote control or 24 V wire feeder. No messy splicing or adapting required.

Wire Feeders



ArcReach® SuitCase® 8

951726 With Bernard® BTB Gun 300 A

951728 With Bernard® Dura-Flux™ gun

ArcReach® SuitCase® 12

951729 With Bernard® BTB Gun 300 A

951731 With Bernard® Dura-Flux™ gun

Portable feeder designed to run off of arc voltage. When paired with an ArcReach power source, provides remote control of the power source without a control cord — saving time and money. See literature M/6.55.



70 Series Wire Feeders

S-74 MPa Plus 951291 Single-wire feeder

D-74 MPa Plus 951292 Dual-wire feeder

Order XR-Aluma-Pro™ Plus gun and U-grooved drive rolls separately to match your aluminum needs. Above models are optimized for Dimension™ 650 and have push-pull capability.

S-74S 951196 Single-wire feeder

S-74D 951198 Single-wire feeder

D-74S 951203 Dual-wire feeder

D-74D 951204 Dual-wire feeder

70 Series feeders feature Posifeed™ wire drive assembly and handle a variety of wires. Each includes a 15-foot Bernard® BTB Gun 400 A (two for dual feeders) and .035/.045-inch V-grooved drive rolls. See literature M/3.0.

Welding Intelligence™



Insight Core™ 14-pin Module 301072

Easy-to-install module brings Insight Core capabilities to your existing fleet. This simplified, Internet-based weld data solution collects, transmits and presents actionable information to any Web-connected device. Insight Core can help you increase productivity, improve weld quality and manage costs.

Coolant Systems

For more information see literature AY/7.2.



Coolmate™ 3

043007 115 V

043008 230 V

For use with water-cooled torches rated up to 500 amps. Unique paddle-wheel indicator, external filter and easy-fill spout.



Coolmate™ 4 042288 115 V

For use with water-cooled torches rated up to 600 amps. Tough molded polyethylene case with carrying handle.

Coolant 043810

Sold in cases of four one-gallon recyclable plastic bottles. Miller coolants contain a base of ethylene glycol and deionized water to protect against freezing to -37 degrees Fahrenheit (-38°C) or boiling to 227 degrees Fahrenheit (108°C). Also contains a compound that resists algae growth.

ArcReach® Heater System



ArcReach Heater Packages

951848 ArcReach Heater CSA model and extension cable

951849 ArcReach Heater CSA model, extension cable and two air-cooled quick wraps

ArcReach Heater Only

301390 CSA model

301591 CE model

The ArcReach Heater is equipped with built-in temperature control allowing for either manual or computer-loaded programming using up to six thermocouples. The ArcReach Heater can run either one or two heating tools (air-cooled cable or air-cooled quick wrap) at the same time. Requires ArcReach Heater extension cable to operate. See literature IN/16.0.

Note: Weld cables are not included.



ArcReach Heater Extension Cable

301451 10 ft. (3 m)

Air-cooled cables or quick wraps connect to the side of the box. Up to six thermocouple sensors connect to the yellow panel, and provide temperature feedback from the piece that is being heated.



Air-Cooled Quick Wrap 301452

The quick wrap works on pipe up to 10-inch (25.4 cm) diameter, and can heat up to a maximum of 600 degrees Fahrenheit (315°C). Requires preheat insulation for temperatures over 392 degrees Fahrenheit (200°C) to protect the tool. Most joints will require two air-cooled quick wraps to be used simultaneously — one on each side of the joint.

Ordering Information

Equipment and Options	Stock No.	Description	Qty.	Price
Dimension™ 650 Power Source Only	907617	380/460 V, 50/60 Hz		
Dimension™ 650 Stationary Package	951638	380/460 V, 50/60 Hz. Includes S-74 MPa Plus feeder, Bernard® BTB Gun 400 A, .035/.045 drive rolls and industrial MIG 4/0 kit		
Dimension™ 650 MIGRunner™ Package	951637	380/460 V, 50/60 Hz. Includes stationary package plus running gear cylinder rack		
Dimension™ 650 ArcReach™ Power Source Only	907617001 907809	380/460 V, 50/60 Hz 575 V, 60 Hz		
Dimension™ 650 ArcReach™ Rack	907701	4-pack rack		
Options and Accessories				
Running Gear Cylinder Rack	300408			
Adapter Cord	301259	115-volt cord for legacy 14-pin accessories. Required to connect to HDC 1500		
Process Control Selector	042872			
Industrial MIG 4/0 Kit	300390	Includes flowmeter regulator with 10 ft. (3 m) gas hose, 10 ft. (3 m) 4/0 feeder weld cable with lugs, and 15 ft. (4.6 m) work cable with 600-amp C-clamp		
Remote Controls				
ArcReach® Stick/TIG Remote	301325	Point-of-use control for stick or TIG welding and gouging with Dimension 650 ArcReach		
Wireless Remote Foot Control	300429	Foot control with wireless 90 ft. (27.4 m) operating range		
Wireless Remote Hand Control	300430	Hand control with wireless 300 ft. (91.4 m) operating range		
RFC-14 HD	194744	Foot control with 20 ft. (6 m) cord and 14-pin plug		
RHC-14	242211020 242211100	Hand control with 20 ft. (6 m) cord and 14-pin plug Hand control with 100 ft. (30.5 m) cord and 14-pin plug		
RCC-14	151086	Fingertip control (east/west)		
RCCS-14	043688	Fingertip control (north/south)		
RMLS-14	129337	Rocker switch		
Extension Cables		See page 6		
Wire Feeders				
ArcReach® SuitCase® 8 and 12		Point-of-use control for MIG or flux-cored welding with Dimension 650 ArcReach. See page 7 and literature M/6.55		
70 Series		See page 7 and See literature M/3.0		
SuitCase® 12RC		See literature M/6.5		
20 Series		See literature M/11.0		
XR-AlumaFeed® SuitCase®		See literature DC/34.0		
XR™ Push-Pull Guns		See literature M/1.71 and M/1.74		
Swingarc™ Boom Feeders		See literature M/13.11		
Welding Intelligence™				
		See page 7		
Coolant Systems				
		See page 7		
ArcReach® Heater System				
ArcReach Heater Packages	951848 951849	Includes ArcReach Heater and extension cable Includes ArcReach Heater, extension cable and two air-cooled quick wraps		
ArcReach Heater Only	301390 301591	Requires extension cable to operate. Included in packages above, CSA Requires extension cable to operate. Not available as a package, CE		
ArcReach Heater Extension Cable Only	301451	10 ft. (3 m)		
Air-Cooled Quick Wrap <i>Requires preheat insulation for temperatures over 392°F (200°C).</i>	301452	For up to 10 in. (25.4 cm) diameter pipes		

Date:

Total Quoted Price:

Distributed by:

