

# Single-Stage Rotary Screw Air Compressors

Constant Speed and Variable Speed Drives  
93-261 kW ■ 125-350 Horsepower

ASK ABOUT OUR  
OIL FREE GUARANTEE!



- Reliable
- Low life cycle cost
- Broad operating range
- Available with variable speed drive
- Available with variable capacity control

  
**SULLAIR**<sup>®</sup>  
Always air. Always there.<sup>®</sup>

# Sullair Capabilities

## Sullair Leadership

Since 1965, Sullair has been recognized around the world as an innovator and a leader in rotary screw compression and vacuum technology. For more than 40 years, Sullair has designed and manufactured its own rotors and air end assemblies at the corporate headquarters in Michigan City, Indiana.

The award-winning rotary screw design sets the industry standards and delivers the quality and reliability one expects from a leader.

## Sullair Technology

Utilizing the most modern technologies, equipment and advanced manufacturing techniques, Sullair designs, manufactures, assembles, and tests the most innovative compressed air and vacuum products in the industry. Sullair products are known around the world for their universally applicable design, outstanding craftsmanship and superior quality.

## Sullair's Statistical Process Control

Sullair's Statistical Process Control (SPC) system monitors rotor quality standards to assure consistent compressor and vacuum performance.

## Sullair's Commitment to Innovation

Underlying Sullair's leadership is a dedication to excellence and a commitment to innovation. Sullair is constantly exploring new ideas and seeking new ways to meet industry's need for increasingly energy efficient compressed air and vacuum solutions.

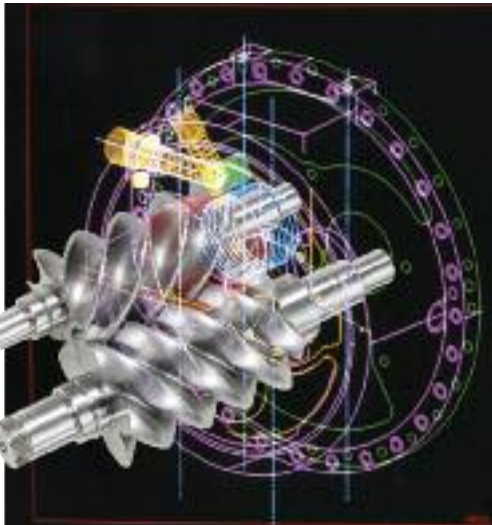

# Sullair Stationary Air Power Systems

Sullair offers total compressed air systems to help compressed air users reduce energy costs and improve productivity by analyzing, managing and controlling their compressed air systems.

Sullair's air systems include: plant air audits, energy efficient products, compressed air system controls, equipment to monitor and manage systems, air distribution products, and after-purchase support.

Each component of the system is carefully matched for capacity and pressure to provide maximum performance and energy efficiency. A total Sullair system provides the user with an air quality guarantee.

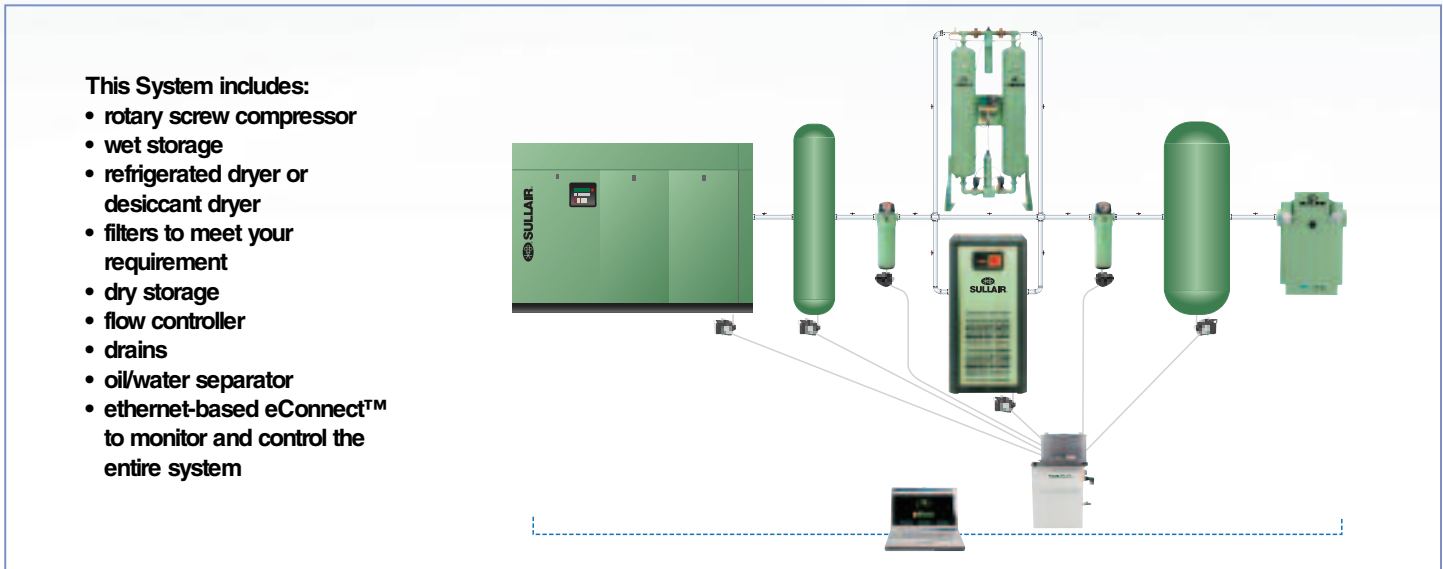

## Sullair Reduces Your Life Cycle Costs



- Equipment
- Maintenance
- Electricity

### Air Compressor Life Cycle Costs

According to *Best Practices for Compressed Air Systems*, Compressed Air Challenge, Second Edition, 2007, energy costs now

represent 82% of the total operating expenses. Energy savings from Sullair's Single-Stage Compressors can significantly reduce life cycle costs.

Sullair's single-stage compressors significantly reduce operating and energy costs over the entire compressor life cycle. Contributing to the energy savings are:

- Sullair's proven air end with the low restriction inlet valve
- High efficiency fan
- Low pressure drop air-fluid separation system to prevent energy loss

Sullair designs deliver cost savings for the life of the product. Improved air filtration translates into:

- Extended separator life
- Improved fluid filter life
- Less lubricant contamination

To reduce fluid disposal costs, we offer our biodegradable Sullube™ 8000-hour fluid, or 24KT™, a long-life fluid that never needs changing.

# Sullair's Air Compressors Provide Reliability and Performance with a Proven Design

## Continuous Duty

Sullair compressors have established themselves as outstanding compressors in the 125 to 350 horsepower range. They offer the inherent reliability of Sullair's rotary screw design to provide continuous-duty performance. Components of every Sullair compressor have been carefully selected to assure complete reliability.

As a result of their rugged, time-proven design, Sullair compressors require only minimum maintenance for optimum performance.

## Rotary Screw Dependability

These models use a single-stage rotary screw air end, featuring Sullair's rugged bearing design: tapered roller bearings on the discharge end and cylindrical roller bearings on the inlet, for high load-carrying capacity.

## Every Sullair Compressor Offers You More:

- The reliable Sullair air end
- Longer average bearing life, designed for over 100,000 hours of service

## Superior Package Design

- Air-cooled or water-cooled models
- Available with or without enclosure
- Designed from the frame up as a complete package—not built with a variety of off-the-shelf components

- Serial communication between the Supervisor Controller and **VSD** eliminates the need for hard wired relays

## Premium Efficient Motor

- Improved energy conservation
- 250,000-hour insulation life

## Broad Operating Range

These compressors are available in 125 to 350 horsepower, with capacities from 457 to 1615 acfm and pressure ratings of 100 to 175 psig.

## Choice of Environmentally Compatible Compressor Fluids

- Long-life, 8000-hour Sullube™ is standard factory fill
- Non-varnishing and biodegradable
- Extended-life 24KT™ is optional
- Routine fluid disposal costs are virtually eliminated

## Multi-Stage air-fluid Separation

- Dual nested separator, reduces lubricant carryover to less than 1 ppm

## Fiberglass Fluid Filter

- Up to 20% more efficient than conventional paper elements.



# The Variable Capacity Control Cuts Energy Costs Dramatically

## Lower Maintenance Costs

As a result of Sullair's rugged, time-proven design, the **VCC** requires only minimum maintenance for optimum performance. There are no troublesome belts or expensive bull gear arrangements to wear out or replace.

## Part-Load Capacity Control Comparisons

The chart shows how a rotary screw compressor with variable displacement reduces power consumption as the compressor load drops. More importantly, it illustrates the substantial power savings at part-load when compared to other capacity control systems.

**PART-LOAD PERFORMANCE ASSESSMENT**

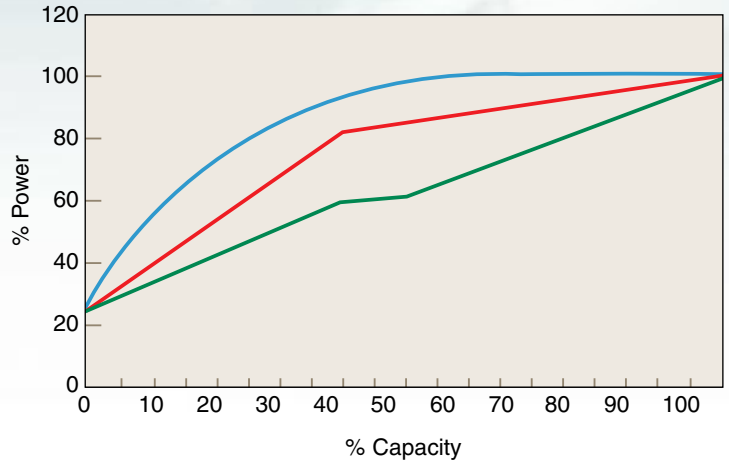

- Single-Stage Lubricated Load/Unload  
(The graph represents one gallon of storage per cfm.)
- Single-Stage Lubricated Inlet Modulation with Blowdown
- Single-Stage Lubricated Variable Displacement



Reference: *Compressed Air and Gas Handbook, 6th Edition, pages 221-223.*



# Sullair's Variable Capacity Control Technology

## Variable Displacement Air End

Sullair's variable displacement air end maintains constant system pressure to the plant. Since the **VCC** compressors use large, efficient, slow running rotors, a lower power consumption is achieved at the top end of capacity. Oil foaming does not occur, air is not wasted to atmosphere, and bearings last longer.

The motor and air end run at optimum speed and therefore maintain optimum efficiency throughout the full variable output range.

Sullair **VCC** compressors react instantly to rapid changes in demand. The effective rotor length is progressively reduced as the demand is reduced which provides the most efficient part-load control system to 50% output.

This system is extremely simple and provides a cost effective, energy-efficient control alternative.

## Variable Capacity Compressors Save You Power

The compressor displacement is matched to the output need. The technology assures precision operation for virtually any part-load point. It provides significant power savings at part-load conditions, compared to compressors using suction throttling, or load/no load control.

## Increases Capacity Control Efficiency

By activating automatically when the unit is operating under partial load, the modulating valve goes down to as low as

40%, and allowing compression of only the required quantity of air, the spiral valve increases the efficiency of the compression process. The ultimate result is greater compression efficiency and reduced power consumption infinitely variable from 50% to 100% capacity.

## Bypass Ports in Stator

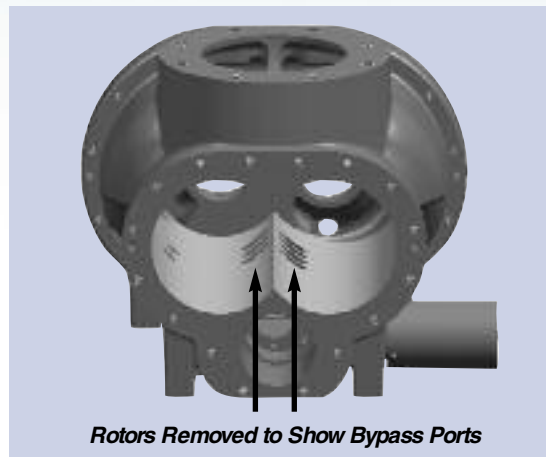

## How the Spiral Valve Operation Works

The compression volume varies to suit the air demand by progressively opening or closing internal bypass ports on the air end.

Capacity is matched to system demand, reducing cycling time and extending component life.

Part-Load capacity and efficiency can produce energy savings up to 17% to 30%.

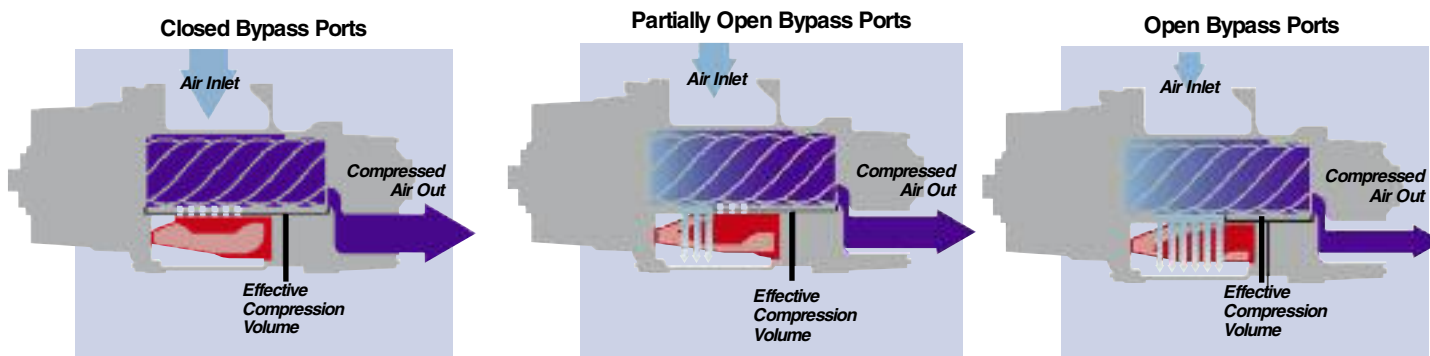

# For the Maximum Energy Efficiency and Operating Consistency, Sullair Air Compressors with **VSD**

## The Sullair Compressors with **VSD** Provide:

- Excellent energy savings
- Relief from potential peak demand charges
- Possible utility company rebate
- DC link choke or 3% line reactor included (model/voltage specific)
- Stable system pressure
- Consistent product quality
- Reduced system air leaks
- Reduced storage requirements
- Flexibility for future growth
- Lowest five-year life cycle cost

## Your Compressed Air System Can Improve Your Bottom Line: 35% Energy Savings in the First Five Years

In just five years, the electrical power cost to operate a standard compressor can be more than six times greater than its purchase price.

### Standard Compressors

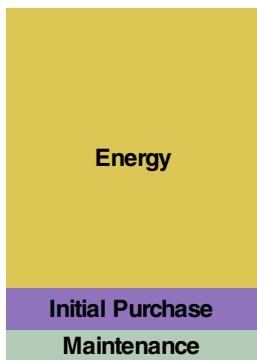

### Sullair's V-200S Compressors

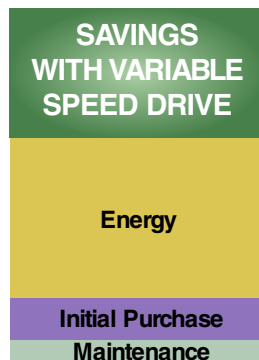

## Total Compressor Flexibility

Sullair's **VSD** compressors provides the flexibility to vary both capacity and pressure. This flexibility makes it possible to "grow" your air system without adding more compressors.



↑ FOR TODAY,      ↑ TOMORROW,      ↑ AND THE FUTURE

## Variable Speed Drive Is the Superior Alternative to Other Compressor Control Systems.

The chart below is a representation of nominal control systems for generic comparative purposes. A detailed and accurate comparison of specific compressor models is available from your Sullair representative or authorized distributor.

**PART-LOAD PERFORMANCE ASSESSMENT**

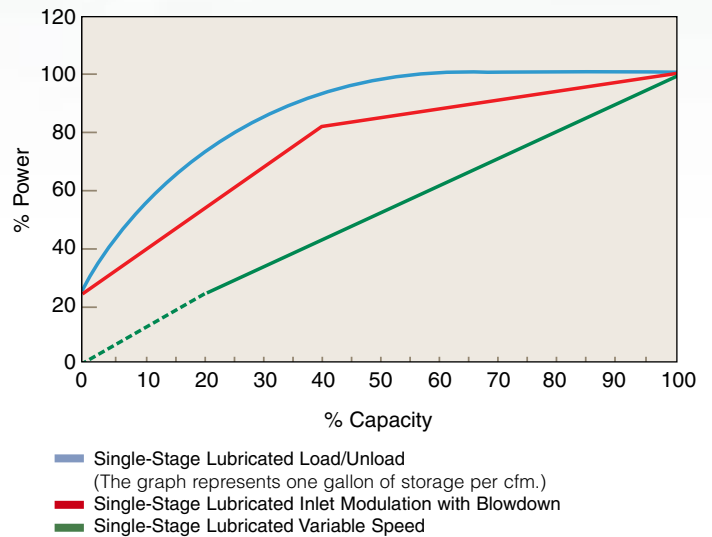

Reference: Compressed Air and Gas Handbook, 6th Edition, pages 221-223.

## Stable System Pressure Improves the Consistency of Your Process to Reduce Product Rejects

- Lowers air system leaks
- Reduces system storage requirements
- Provides increased energy savings to increase profits

### Standard Compressors

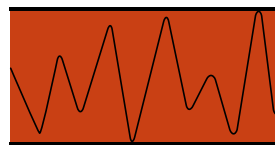

### Sullair's VSD Compressors



## Soft Start is Standard with Unlimited Starts and Stops

- No need for Wye Delta and other soft starters
- No need to control the number of hot or cold starts
- Unlimited starts and stops save electrical costs
- Avoids high electrical current at start-up

## **VSD** Avoids Potential Peak Demand Charges

**VSD** compressors provide the highest power factor over the entire frequency range, often avoiding utility company penalties.

# The Sullair Single-Stage Compressors: LS-200S, LS-25S, VCC-200S, VCC-250S, V-200S and V-250S

## Sullair Supervisor™ Controller

- Micro-processor controller has simple graphic illustration of monitored functions and an easy to read keypad
- Constant readout of pressure and temperature
- On-demand readout of all operating and maintenance conditions
- Monitors key functions and safety shutdowns
- Power failure auto re-start
- Dual control, provides automatic start-stop operation
- Lead-lag and sequencing with multiple compressors
- Service and preventive maintenance schedule
- “Run”, “Loaded” and “Consumable Parts” hours
- Fault history with sensor readings

\* Model V-250S uses the WS Controller

- “Help” key provides built-in troubleshooting
- Remote monitoring capability
- V250S uses WS Controller

## Cooling

- Air-cooled units have updraft coolers for ease of installation and heat recovery capabilities
- Water-cooled units use shell and tube heat exchanger

## Multi-Stage Air-Fluid Separation

- Dual nested Optimizer™ separator elements reduce fluid carry-over to less than 1 ppm as measured prior to aftercooler
- Reduced carryover lowers make-up fluid costs
- Pleated Optimizer™ elements lower initial pressure drop for greater efficiency and extend life of the elements



## Optimalair™ Inlet Filter

- Includes remote air intake connection
- Provides finest inlet filtration in the industry (0.4 microns using Fine Fiber Technology)
- Protects premature failure of key components
- Extends separator, fluid filter and fluid life

## Fiberglass Fluid Filter

- Aircraft-quality media provides better filtration
- Up to 20% more efficient than conventional paper elements
- Lengthens the life of the compressor

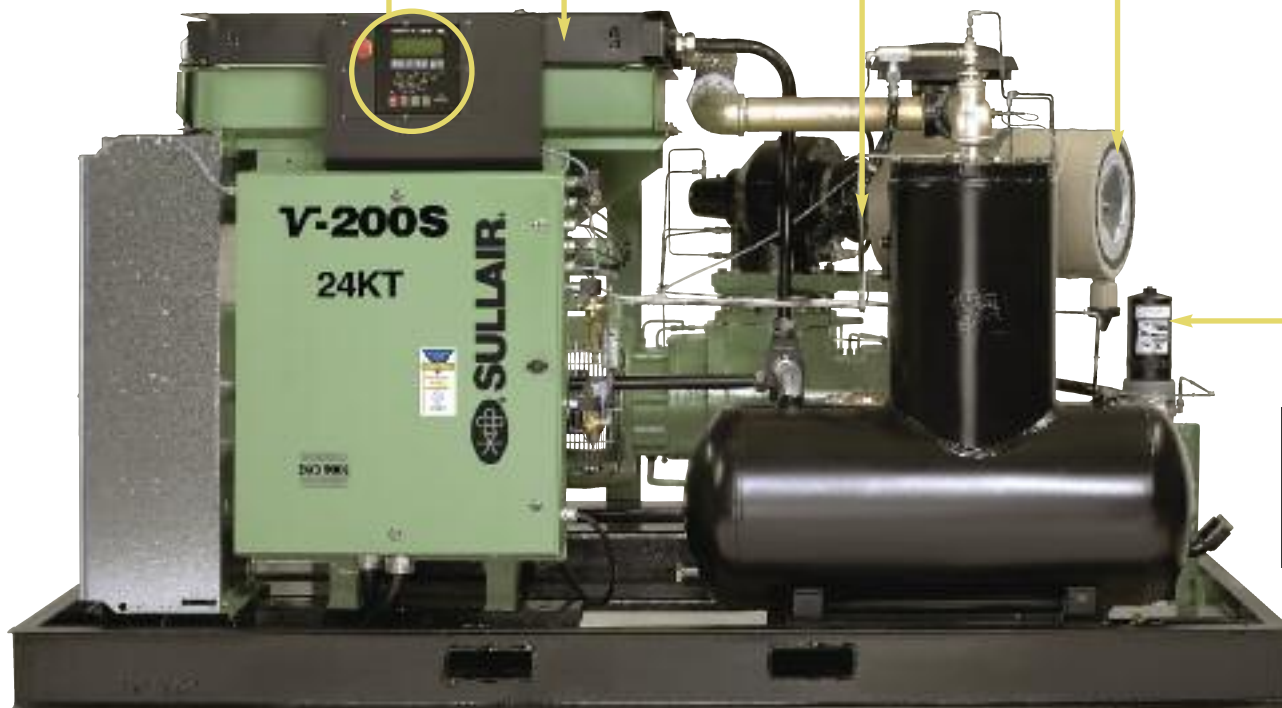

Open and enclosed models available.



### **Superior Package Design**

- SAE O-ring fittings are standard
- Number of fittings are reduced
- Designed for continuous duty
- Aftercooler, moisture separator and electric drain
- Air-cooled or water-cooled models are available

### **Sullair's Variable Capacity**

- Superior alternative to other compressor control systems
- Lowest five-year life cycle cost
- Stable system pressure
- Flexibility for future growth

### **Flange-Mounted Motor and Air End\***

- Up to 5% energy savings over belt drive
- Eliminates maintenance expense associated with V-belts
- NEMA frame design
- Provides positive alignment
- Optimizes bearing life of air end and motor

\*Not standard on LS-25S.

### **Premium Efficient Motor**

- Improved energy conservation
- Five-year warranty
- Direct coupled design for extended bearing life
- 250,000-hour insulation life
- NEMA frame design

### **The Variable Capacity Sullair Air End**

- Features Sullair air end and spiral valve
- Lowers part-load operating costs
- Reduces cycling duty on package components

### **Select One of These Long-Life Fluids...**

#### **Sullube™ is Standard Factory Fill**

- Biodegradable
- One-year or 8000-hour service life
- Reduces fluid disposal costs

#### **24KT™ is Optional**

- Eliminates annual fluid changes
- Eliminates annual fluid disposal costs

#### **Free Fluid Sampling and Analysis Program with Either Fluid.**

#### **Sullair's Versatile Control System**

- Matches output to demand
- Stabilizes system pressure
- Minimizes need for an air receiver
- Extends package life

#### **Bearing Fluid Reservoirs**

- Ensure fluid is available at start-up
- Extends air end life



# Sullair Air Quality Guarantee



## Two Levels of Air Quality

Sullair recognizes that the requirements for air quality vary according to each compressed air application. For this reason, Sullair provides compressed air systems that achieve two distinct levels of air quality and a guarantee for each.

### Sullair Stationary Air Power System

The Sullair Stationary Air Power System matches a Sullair compressor, a Sullair dryer and Sullair filters. Sullair assures that its System will meet specific performance levels throughout its operational life. We offer a one-year test/review period, backed by a purchase refund guarantee, to verify the performance of the Sullair System.

### Select the System

Select the air quality level to meet your plant air or process requirements. You can be assured that the quality of air from the Sullair System you specify will remain consistent for the life of the equipment. Sullair guarantees it... and that's as good as gold.

### The Sullair Oil-Free Air Quality Guarantee

The System consists of a Sullair compressor, Sullair dryer, and Sullair filters. The compressed air from this system contains particulates no larger than .01 micron, including coalesced liquid water and lubricants.

Maximum remaining oil aerosol content is 0.01 parts per million by weight (ppm/w) @ 70°F, including oil vapor. The air from this Sullair System meets the most stringent ISO standard (ISO 8573.1, Class 1 for oil vapor and Class 2 for particulate) for air quality.

### The Sullair Critical Air Quality Guarantee

The compressed air from this Sullair System exceeds the ISO standard (ISO 8573.1, Class 1 for oil vapor and Class 2 for particulate). The System includes a Sullair compressor, Sullair dryer, and Sullair filters. The odor-free compressed air from this system contains particulates no larger than 0.01 micron, including water and oil aerosol content of 0.01 parts per million by weight (ppm/w) @ 70°F. The remaining oil vapor content is less than 0.003 ppm/w.

To get more information on Sullair's Air Quality Guarantee, please contact your Sullair distributor.

These Systems are not intended to remove carbon monoxide, methyl isocyanate or other noxious, corrosive or toxic gases, vapors or fumes. The System does not provide breathing air.

## Air Quality is One of the Best in the Industry

### Lowest Fluid Carryover

While others claim a low carryover of 5 ppm or more, Sullair's single-stage compressors offer a carryover rate less than 1 ppm—the lowest in the industry. Sullair's MSS, Multi-Stage Separation, uses a sump design, which allows use of oversized dual nested separators.

### Sullair Optimizer™ Air-Fluid Separator

A high efficiency separator that will pay for itself (during the life of the separator) in reduced compressor fluid carryover and electrical power consumption.

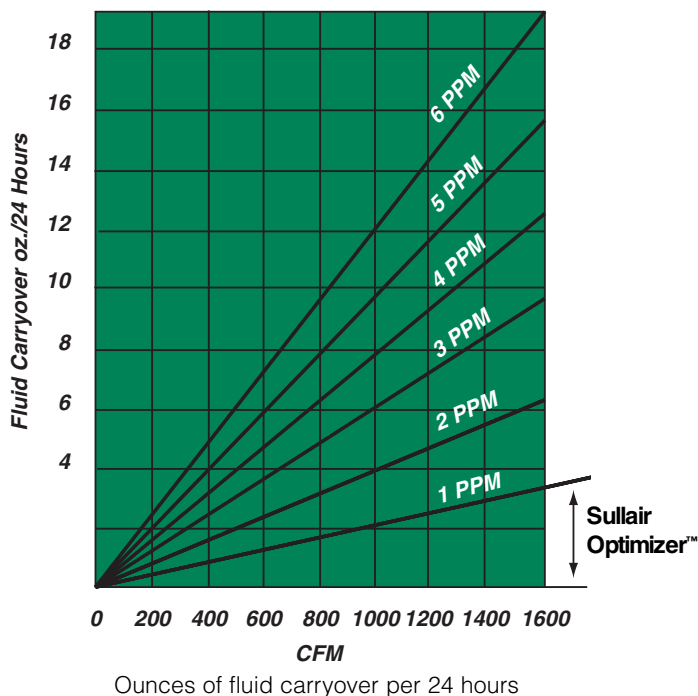

# Specifications

60Hz Motor Performance LS-200S and LS-25S			Constant Speed Drive Full-Load Capacity								Enclosed Dimensions and Weights							
Model	Motor		acfm@ m³/min@ 100 psig 6.8 bar		acfm@ m³/min@ 125 psig 8.6 bar		acfm@ m³/min@ 150 psig 10.3 bar		acfm@ m³/min@ 175 psig 12 bar		Length		Width		Height		Weight	
	hp	kW									in	mm	in	mm	in	mm	lbs	kg
LS-200S-125	125	93	647	18.3	587	16.9	506	14.3	457	12.9	100	2540	60	1524	68	1727	5250	2381
LS-200S-150	150	112	752	21.2	683	19.3	631	17.8	570	16.1	100	2540	60	1524	68	1727	5250	2381
LS-200S-200*	200	149	980	27.7	897	25.4	768	21.7	720	20.3	120	3048	72	1828	68	1727	7450	3379
LS-25S-250	250	186	1218	34.4	1075	30.4	–	–	–	–	154	3911	78	1981	86	2184	10760	4880
LS-25S-300	300	224	1480	41.9	1330	37.6	–	–	–	–	154	3911	78	1981	86	2184	10760	4880
LS-25S-350	350	261	1615	45.7	1460	41.3	–	–	–	–	154	3911	78	1981	86	2184	11110	5039

60Hz Motor Performance VCC-200S and VCC-25S			Constant Speed Drive with Variable Capacity Control Full-Load Capacity								Enclosed Dimensions and Weights							
Model	Motor		acfm@ m³/min@ 100 psig 6.8 bar		acfm@ m³/min@ 125 psig 8.6 bar		acfm@ m³/min@ 150 psig 10.3 bar		acfm@ m³/min@ 175 psig 12 bar		Length		Width		Height		Weight	
	hp	kW									in	mm	in	mm	in	mm	lbs	kg
VCC-200S-125	125	93	647	18.3	587	16.9	506	14.3	457	12.9	100	2540	60	1524	68	1727	5250	2381
VCC-200S-150	150	112	752	21.2	683	19.3	631	17.8	570	16.1	100	2540	60	1524	68	1727	5570	2526
VCC-200S-200*	200	149	980	27.7	897	25.4	768	21.7	720	20.3	120	3048	72	1828	68	1727	7450	3379
VCC-250S-200*	200	149	1025	29.0	910	25.7	–	–	–	–	120	3048	72	1828	68	1727	8750	3968
VCC-25S-250	250	186	1218	34.4	1075	30.4	–	–	–	–	154	3911	78	1981	86	2184	10760	4880
VCC-25S-300	300	224	1480	41.9	1330	37.6	–	–	–	–	154	3911	78	1981	86	2184	10760	4880
VCC-25S-350	350	261	1615	45.7	1460	41.3	–	–	–	–	154	3911	78	1981	86	2184	11110	5039

60Hz Motor Performance V-200S			Variable Speed Drive Full-Load Capacity with Variable Capacity Control								Enclosed Dimensions and Weights							
Model	Motor		acfm@ m³/min@ 100 psig 6.8 bar		acfm@ m³/min@ 125 psig 8.6 bar		acfm@ m³/min@ 150 psig 10.3 bar		acfm@ m³/min@ 175 psig 12 bar		Length		Width		Height		Weight	
	hp	kW									in	mm	in	mm	in	mm	lbs	kg
V-200S-125	125	93	633	17.9	576	16.3	–	–	–	–	100	2540	60	1524	68	1727	5330	2417
V-200S-150	150	112	757	21.4	696	19.7	–	–	–	–	100	2540	60	1524	68	1727	5650	2562
V-200S-200*	200	149	967	27.3	888	25.1	787	22.2	743	21.0	120	3048	72	1828	68	1727	7800	3538

60Hz Motor Performance V-250S			Variable Speed Drive Full-Load Capacity with Variable Capacity Control								Enclosed Dimensions and Weights							
Model	Motor		acfm@ m³/min@ 100 psig 6.8 bar		acfm@ m³/min@ 125 psig 8.6 bar		acfm@ m³/min@ 150 psig 10.3 bar		acfm@ m³/min@ 175 psig 12 bar		Length		Width		Height		Weight	
	hp	kW									in	mm	in	mm	in	mm	lbs	kg
V-250S-250	250	186	1195	33.8	1085	30.7	–	–	–	–	154	3511	78	1981	86	2184	10760	4880
V-250S-300	300	224	1400	39.6	1305	36.9	–	–	–	–	154	3511	78	1981	86	2184	10760	4880
V-250S-350	350	261	1580	44.7	1435	40.6	–	–	–	–	154	3511	78	1981	86	2184	11110	5039

50Hz Motor Performance LS-200S and LS-25S			Constant Speed Drive Full-Load Capacity								Enclosed Dimensions and Weights							
Model	Motor		m³/min@ acfm@ 6.8 bar 100 psig		m³/min@ acfm@ 8.6 bar 125 psig		m³/min@ acfm@ 10.3 bar 150 psig		m³/min@ acfm@ 12 bar 175 psig		Length		Width		Height		Weight	
	kW	hp									mm	in	mm	in	mm	in	kg	lbs
LS-200S-125	93	125	17.4	614	15.9	560	14.6	515	13.1	464	2540	100	1524	60	1727	68	2381	5250
LS-200S-150	112	150	21.1	745	19.2	678	17.0	601	15.3	542	2540	100	1524	60	1727	68	2381	5250
LS-200S-200*	149	200	25.6	951	25.0	884	22.4	791	20.5	725	3048	120	1828	72	1727	68	3379	7450
LS-25S-200	149	200	28.6	1010	22.9	810	22.5	795	–	–	3911	154	1981	78	2184	88	4880	10760
LS-25S-250	186	250	34.7	1225	–	–	27.7	980	–	–	3911	154	1981	78	2184	88	4880	10760
LS-25S-300	224	300	41.1	1452	37.6	1330	36.9	1305	–	–	3911	154	1981	78	2184	88	4880	10760
LS-25S-350	261	350	44.2	1563	40.7	1438	–	–	–	–	3911	154	1981	78	2184	88	5039	11110

50Hz Motor Performance VCC-200S and VCC-25S			Constant Speed Drive with Variable Capacity Control Full-Load Capacity								Enclosed Dimensions and Weights							
Model	Motor		m³/min@ acfm@ 6.8 bar 100 psig		m³/min@ acfm@ 8.6 bar 125 psig		m³/min@ acfm@ 10.3 bar 150 psig		m³/min@ acfm@ 12 bar 175 psig		Length		Width		Height		Weight	
	kW	hp									mm	in	mm	in	mm	in	kg	lbs
VCC-200S-125	93	125	17.4	614	15.9	561	14.6	515	13.1	463	2540	100	1524	60	1727	68	2381	5250
VCC-200S-150	112	150	21.1	745	19.2	678	17.0	600	15.3	540	2540	100	1524	60	1727	68	2526	5570
VCC-200S-200*	149	200	26.5	951	25.0	884	22.4	791	20.5	725	3048	120	1828	72	1727	68	3379	7450
VCC-250S-200*	149	200	28.6	1010	–	–	–	–	–	–	3048	120	1828	72	1727	68	3968	8750

\*A remote cooler must be used with 200 hp and 250 hp (149 kW and 186 kW) compressors using 24 KT. Capacity per CAGI / PNEUROP PN2CPTC2 (Annex C to ISO 1217)

24KT available for 100 and 125 psig – 6.8 bar and 8.6 bar offerings  
Data subject to change without notice.

# Sullair's Compressed Air Products

www.sullair.com



Fundamental to Sullair's leadership is a dedication to reduce not only the amount of natural resources consumed to create energy, but to minimize environmental impact, in both the manufacture and use of all our products. We are constantly exploring new ideas and seeking new technologies to meet the ever-increasing need for high quality, energy-efficient compressed air products and environmental sustainability.



© Copyright 2012 Sullair. All rights reserved.  
The color green is a registered trademark of Sullair.  
Specifications subject to change without notice.  
**LS16E 1211R**



 The paper used in printing this literature was manufactured using recycled fiber, either pre-consumer or post-consumer waste, therefore less harmful to the environment because less virgin fiber is used, thereby reducing tree harvesting, water usage, energy consumption, emission of greenhouse gases and pollution.