

# Spicer® C270 Torque Converter

93 to 149 kW (125 to 200 hp)



**SPICER®**  
*Off-Highway Systems*



Engineered for reliability in construction, mining, and material-handling machinery, the Spicer® C270 torque converter offers a full range of beneficial features.

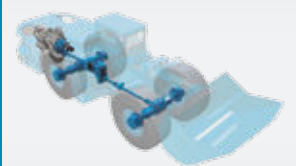
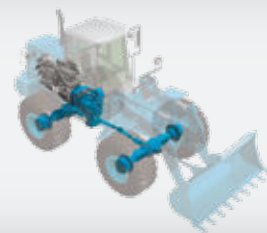

# Spicer® C270 Torque Converter

93 to 149 kW (125 to 200 hp)

The Spicer® C270 torque converter is designed for vehicle applications in construction, mining, material-handling and other industrial applications. The highly reliable C270 offers flexible options to match most engine requirements, maximizing machine performance and efficiency.

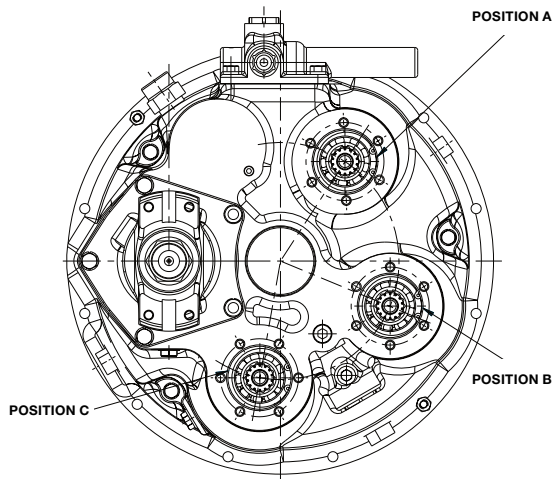
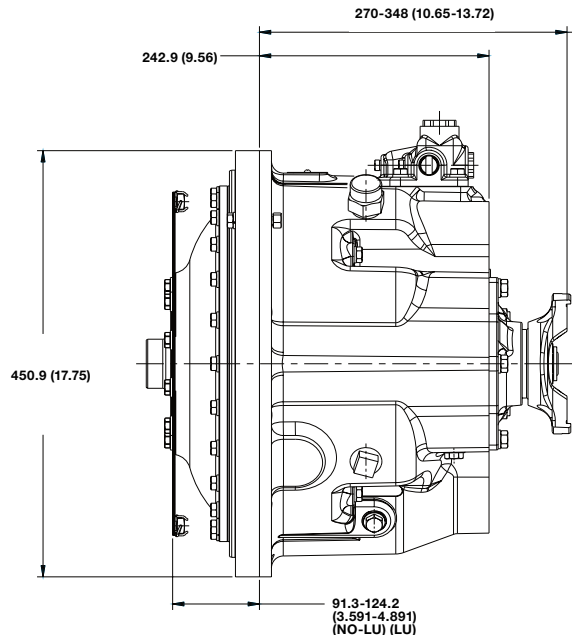

Converter	
Flywheel Housing Size	SAE No. 3 (Dry)
Flex Plate Drive Bolt Circle Options mm (in)	333.24, 342.9, 381, 431.8 (13.12, 13.5, 15, 17)
Input Power kW (hp)	93 to 149 (125 to 200)
Torque Capacity Nm (ft-lb)	743 (550)
Input Maximum (RPM)	3300
Torque Converter Diameter mm (in)	279.4, 304.8, 330.2 (11, 12, 13)
Stall Torque Ratio Options	1.82 to 3.12

Pump Drive	
SAE Mounting Size	SAE Spline
"A" – 2-Bolt	9-Tooth, 16/32 Pitch
"B" – 2- or 4-Bolt	13-Tooth, 16/32 Pitch
"C" – 2- or 4-Bolt	14-Tooth, 12/24 Pitch
6-Bolt	
2.625" Pilot	9-Tooth, 16/32 Pitch
Pump Drive Ratings Nm (ft-lb)	Maximum Continuous – 244 (180) Maximum Intermittent – 298 (220)
Pump Drive Ratio and Rotation	Standard: 0.952:1 Overdrive – Rotates Opposite Engine Optional: 1.135:1 Underdrive – Rotates Opposite Engine

Flanges	
Spicer	1410 Yoke, 1480 Yoke, 1550, 1550 Yoke, 1550M
Mechanics	4C, 5C, 6C
GWB	387/20, 387/30, 155kV70

Weight	
Without Lock-up kg (lb)	117.9 (260)
With Lock-up kg (lb)	140.6 (310)

## Features and Benefits

- Straight-through drive
- Offset drive
- SAE "A", "B" and "C" pump mounting
- Lock-up
- Engine inductive sensor
- Turbine inductive sensor
- Flex plate drive
- Free wheel
- SAE flywheel housing 3
- High operating efficiency
- Engineered specifically for off-highway equipment
- Optimized cast blading results in high efficiencies
- Flexible installation

Sales Office – Italy  
Zona Industriale  
Arco, Italy 38062

[www.dana.com/offhighway](http://www.dana.com/offhighway)



**SPICER®**

Off-Highway Systems

## Application Policy

Capacity ratings, features, and specifications vary depending upon the model and type of service. Application approvals must be obtained from Dana; contact your representative for application approval. We reserve the right to change or modify our product specifications, configurations, or dimensions at any time without notice.