

NOZZLE CHART	
NOZZLE ID	NPT SIZE
N1	1/4
N2	1/2
N3	1
N4	2

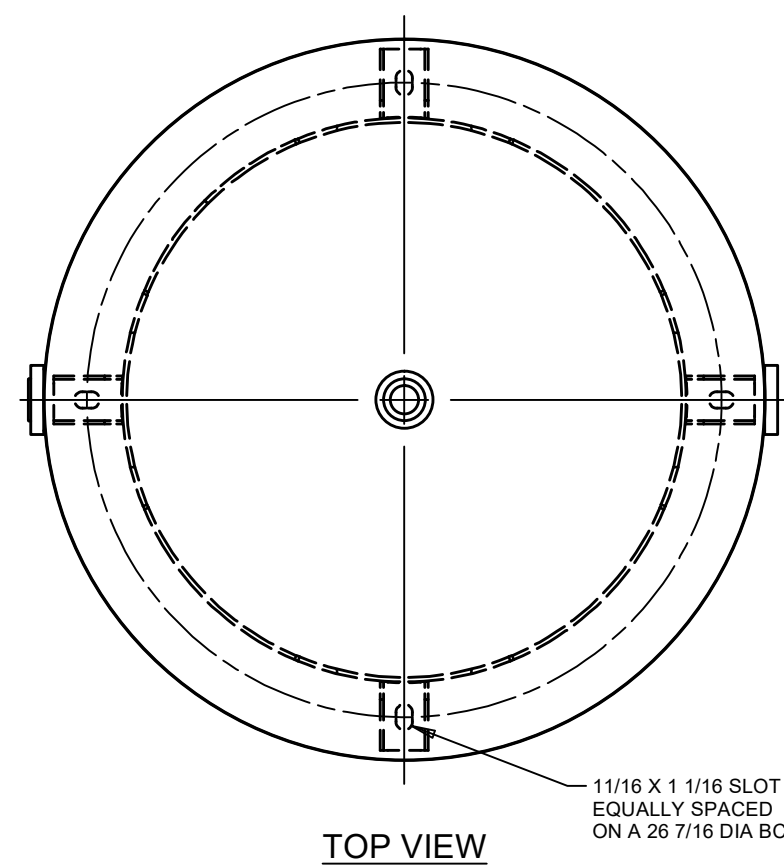
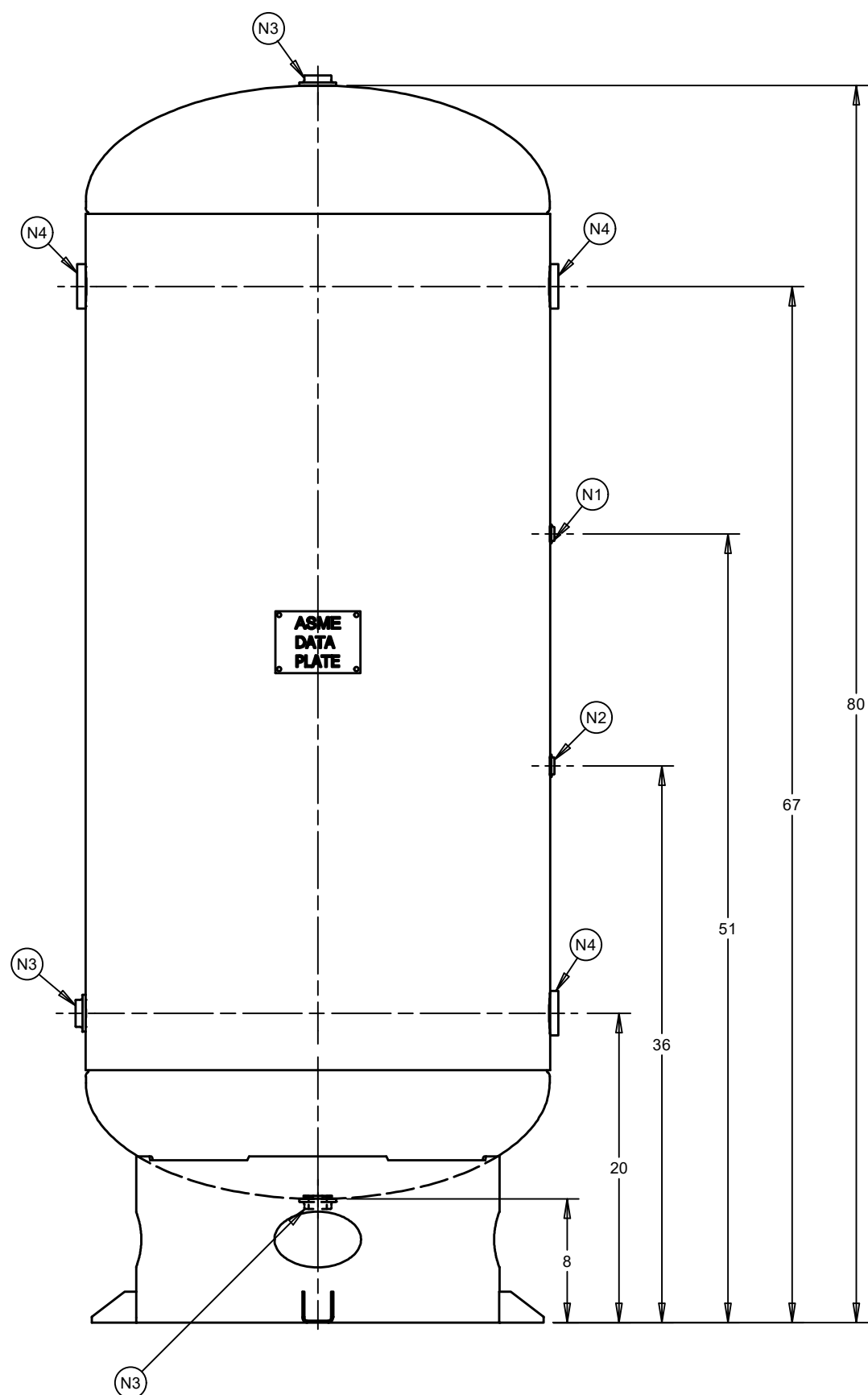

DESIGN INFORMATION	
SPECIFICATION	VALUE
DIAMETER O.D./I.D.	30 O.D.
MAWP	200 PSI AT 400°F
MDMT	-20°F AT 200 PSI
CAPACITY	APPROX 200 GALLONS
SHIPPING WEIGHT	473 LBS
CRN	L4036.5C

TITLE VERTICAL AIR RECEIVER					
CUSTOMER STOCK		DRAWN KAT 9/7/2016	CHECKED DMM 10/7/2016	DRAWING NO <b>A10051</b>	REV <b>D18</b>
TYPE ASME		SIZE: B SHEET 1 OF 1			

D18	ISSUED		
REV	DESCRIPTION	BY	DATE

(BUILT IN ACCORDANCE WITH LATEST EDITION OF SECTION VIII DIV 1 ASME CODE)

THIS DRAWING & SPECIFICATIONS ARE PROPERTY OF SPVG AND MAY NOT BE COPIED, REPRODUCED, OR USED IN WHOLE OR PART, AS A BASIS FOR DESIGN MANUFACTURE OR SALE WITHOUT PRIOR PERMISSION FROM SPVG.